

The guide to safe use of power-operated paper-cutting guillotines



This is a free-to-download, web-friendly version of The guide to safe use of power-operated paper-cutting guillotines (Second edition edition, published 1999). This version has been adapted for online use from HSE's current printed version.

You can buy the book at www.hsebooks.co.uk and most good bookshops.

ISBN 978 0 7176 1707 4

Price £7.50

This publication is produced by the Printing Industry Advisory Committee and is aimed at helping all those who work in the printing industry, including employers, employees and suppliers, to identify the main causes of accidents and hazards associated with power-operated paper cutting guillotines and how to eliminate the hazards and control the risks.

The guidance also explains the level of knowledge and experience the engineers need and also the technical standards relevant to both existing machines and second-hand ones. It also gives advice to manufacturers and suppliers of new machines.

© *Crown copyright 1999*

First published 1988

ISBN 978 0 7176 1707 4

All rights reserved. No part of this publication may be reproduced, stored in a retrieval system, or transmitted in any form or by any means (electronic, mechanical, photocopying, recording or otherwise) without the prior written permission of the copyright owner.

Applications for reproduction should be made in writing to:
The Office of Public Sector Information, Information Policy Team,
Kew, Richmond, Surrey TW9 4DU or e-mail: licensing@opsi.gov.uk

This guidance is issued by the Health and Safety Executive. Following the guidance is not compulsory and you are free to take other action. But if you do follow the guidance you will normally be doing enough to comply with the law. Health and safety inspectors seek to secure compliance with the law and may refer to this guidance as illustrating good practice.

Members of the Printing Industry Advisory Committee (PIAC)

Nominated by the CBI

| | |
|------------------------|--|
| Mr D E Barker | Newspaper Society |
| Mr G Cooper | Newspaper Society |
| Mr J Fuller | British Printing Industries Federation |
| Mr G McNab | Scottish Print Employers Federation |
| Mr B Purkis | Newspaper Publishers Association |
| Mr W Stothard | British Printing Industries Federation |
| Mrs S Whittaker | Newspaper Publishers Association |
| Mr I Wilcock | British Printing Industries Federation |

Nominated by the TUC

| | |
|------------------------|---------------------------------|
| Mr D Barker | Graphical Paper and Media Union |
| Mr T Gopsil | National Union of Journalists |
| Mr M Griffiths | Graphical Paper and Media Union |
| Mr R A Hudspith | Graphical Paper and Media Union |
| Mr A Metcalf | Graphical Paper and Media Union |
| Mr D Spencer | Graphical Paper and Media Union |
| Mr P Taylor | Graphical Paper and Media Union |

HSE

| | |
|-----------------------|--|
| Mr A D Porter | Chairman, Health and Safety Executive |
| Mr M D Wilcock | Secretary, Health and Safety Executive |

Members of PIAC Guillotines Working Group

| | |
|--------------------------|---|
| Mr N Bayley | Picon Ltd |
| Mr P Borsos | E B Gallon/Phaselec Ltd |
| Mr M Brown | Oscar Freidheim Ltd |
| Mr B Clarke | Health and Safety Executive |
| Mr J Fairbrass | Secretary, Health and Safety Executive |
| Mr J Fuller | Jet Stationary Company Ltd |
| Mr R A Hudspith | Graphical Paper and Media Union |
| Mr G T Law | Safety Assessment Federation (SAFed)/Zurich Engineering |
| Mr R Lee | Health and Safety Laboratories |
| Mr S B Longbottom | Health and Safety Executive |
| Mr B Preston | Kalamazoo Group |
| Mr S Rickman | Heidelberg Graphic Equipment Ltd |
| Mr M Ward | Pershke Price Service Organisation Ltd |
| Mr I Wilcock | British Printing Industries Federation |
| Mr M D Wilcock | Chairman, Health and Safety Executive |

Contents

| | |
|--|----|
| Preface | 7 |
| What is PIAC? | 7 |
| Why does PIAC exist? | 7 |
| Introduction | 8 |
| How to use this book | 8 |
| Section 1 - Machinery description: hazards and safeguards | 10 |
| Hazards | 10 |
| Knife | 10 |
| Clamp | 11 |
| Machine table | 11 |
| Backgauge | 12 |
| Drive machinery | 12 |
| Operation | 12 |
| Controls | 12 |
| Two-hand control devices | 12 |
| Backgauge handwheel | 13 |
| Types of safeguard | 13 |
| Front guards | 13 |
| Active opto-electronic protective devices (AOPD)(photoelectric guards) | 13 |
| Interlocking guards | 17 |
| Falling finger guards | 17 |
| Automatic sweepaway guards | 17 |
| Body-push guards | 21 |
| Rear guards | 21 |
| Safeguarding of ancillary handling equipment | 22 |
| Pile lift/hoist | 23 |
| Scissor lifts | 23 |
| Joggers and auto-stacking tables | 23 |
| De-stackers, re-stackers and turning units | 23 |
| Section 2 - User requirements | 24 |
| Introduction to section | 24 |
| Maintenance and inspection records - logs | 25 |
| Buying a guillotine | 25 |
| Upgrading guillotines | 26 |
| Locating and siting machines | 26 |
| Commissioning inspections and tests | 27 |
| Instruction manuals | 27 |
| Training and safe working practices | 28 |
| Startup procedure | 28 |
| Gauging | 28 |
| Knife cleaning | 28 |
| Knife changing | 29 |
| Routine maintenance, inspection and testing | 30 |
| In-house daily/shift/after-knife-change maintenance checks | 31 |
| All machines with two-hand control | 31 |
| ESPEs | 32 |
| Interlocking guards | 32 |
| Monthly/after-knife-change maintenance checks | 32 |
| Sweepaway guards | 32 |
| Interlocking guards | 32 |
| Six-monthly inspection and check | 33 |
| Engineer's competency guide | 33 |

| | |
|-------------------------------------|----|
| When not to wait six months | 33 |
| Ancillary handling equipment | 34 |
| Modifications and servicing | 34 |
| Safe working practice | 34 |

Section 3 - Engineer's responsibilities and competence 35

| | |
|--|----|
| Legal requirements | 35 |
| Competence | 35 |
| Accreditation of inspecting engineers | 35 |
| Assessment of competence | 36 |
| Inspection and testing of guillotines | 36 |
| All machines | 36 |
| ESPEs | 37 |
| Interlocking guards | 37 |
| Sweepaway guards | 37 |

Section 4 - Technical standards for existing machinery and the supply of second-hand machinery 39

| | |
|---|----|
| Introduction | 39 |
| Guillotine instruction manual and log | 40 |
| Technical standards | 40 |
| Electrical safety and controls | 40 |
| Gauging pedal | 40 |
| Two-hand control devices | 40 |
| Programmable electronic systems | 41 |
| Front guards | 41 |
| ESPE | 41 |
| Performance standards for pre-1985 guillotines | 41 |
| Performance standards for post-1985 guillotines | 42 |
| Machine primary control elements | 44 |
| Stopping performance monitoring | 45 |
| Overrun detection | 45 |
| Positioning of the AOPD relative to the cutting stick | 46 |
| Interlocking guards | 46 |
| Automatic sweepaway guards | 46 |
| Brake and clutch design | 46 |
| Hydraulic design | 47 |
| Control valves | 47 |
| Gravity fall | 48 |

Section 5 - Additional information for suppliers of new machines 49

| | |
|--|----|
| Suppliers' responsibilities | 49 |
| Manufacturers' responsibilities | 50 |
| Conformity assessment | 50 |
| New machines - harmonised standards | 50 |

Appendices

| | |
|--|----|
| 1 Contents of instruction manual | 52 |
| 2 Sample logs | 53 |
| 3 Guillotine safety checklists | 58 |
| 4 Glossary | 62 |
| 5 Extract from BPIF booklet <i>Guarding of guillotines and trimmers</i> | 64 |
| 6 Extract from the HSE booklet <i>Electro-sensitive safety devices for friction-clutch press brakes</i> | 67 |
| 7 Method for determining the position of the AOPD relative to the cutting stick | 69 |

References 71

Further information 74

Preface

What is PIAC?

The Printing Industry Advisory Committee (PIAC) was formed in July 1979 to advise the Health and Safety Commission (HSC) on matters concerning the printing industry. The members of PIAC are nominated by the CBI and the TUC and appointed by HSC to work together with HSE to advise the industry on health and safety.

Why does PIAC exist?

Every year people are seriously injured working in the printing industry. Many others suffer ill health which prevents them from doing their normal work. Almost all these cases could be prevented.

PIAC is determined to take action to improve health and safety performance in the printing industry. As part of this process PIAC has developed this guidance book to help those responsible for health and safety in the industry understand their responsibilities and take the necessary action.

This book is in a series of new health and safety guidance for printing. The series will be developed over the next few years. The aim of the series is to help all those in printing, including employers, employees and suppliers, to identify the main causes of accidents and ill health and to explain how to eliminate the hazards and control the risks. Every book in the series will be identified by the logo on the front cover.

Introduction

1 Power-operated paper-cutting guillotines are widely used throughout the paper manufacturing, conversion, printing and print-finishing industries. Serious accidents have been caused by knives and clamps including amputation, bruising and crushing. These injuries continue to occur in situations where they could easily have been prevented.

2 This book contains practical advice on the safeguarding of these guillotines. It will help if you use guillotines or have a role in the design, manufacture, supply, testing, examination and installation of guillotines and their safeguards. It gives guidance on legal duties and provides technical advice on different safeguarding methods, relevant standards, maintenance, testing, and training.

How to use this book

3 The advice in this book is divided into five sections:

- Section 1 - gives information on machine and safeguard types, hazards and accidents;
- Section 2 - gives advice for the user;
- Section 3 - gives guidance on competencies (ie a combination of technical knowledge, awareness and experience) that should be acquired by guillotine engineers so that they can effectively fulfill their responsibilities;
- Section 4 - gives information on technical standards for existing machines and those supplied second hand;
- Section 5 - gives information and advice for the manufacturers and suppliers of new machines.

4 **Users** should see Section 1 for advice on:

- the hazardous parts of your guillotine and associated handling equipment;
- types of safeguards commonly used;
- the checks you should make to ensure that the equipment is adequately safeguarded.

Users should read Section 2 for advice on:

- their legal responsibilities;
- buying a guillotine - what to look for in supplier's literature to make sure the intended purchase is safe to use and complies with legal requirements;
- training employees;
- safe systems of work for knife changing and cleaning;
- maintaining the guillotine and carrying out the necessary regular safety checks on guard performance;
- selecting a competent engineer to carry out six-monthly inspections and testing;
- maintaining an up-to-date log for each guillotine.

5 **Guillotine engineers/engineer surveyors** who carry out inspections and testing, servicing or refurbishment of guillotines, should read Section 3 for advice on:

- their legal responsibilities;
- their necessary level of competence;
- the content of the six-monthly inspection and test at paper-cutting guillotines.

They should also read Section 4 for advice on:

- the technical performance standards to which guillotines should comply when inspected and tested.

6 **Used guillotine suppliers** who run a business which refurbishes machines for resale or simply sell on used guillotines in the UK, should read Section 4 for advice on:

- their legal responsibilities;
- the technical performance standards for second-hand machines and the upgrading work necessary;
- the technical standards needed to work to when upgrading guillotines;
- providing an up-to-date maintenance log.

7 **Manufacturers and suppliers** of new guillotines will find advice in Section 4 on:

- performance standards for existing guillotines.

They will also find advice in Section 5 on:

- their legal responsibilities;
- the relevant current European Standards.

8 The book does not repeat guidance already published separately by HSE. Relevant publications are listed in the *Reference* section. You can obtain up-to-date information on HSE publications from HSE's InfoLine.

9 This book replaces the guidance previously contained in the PIAC booklet *Safety at power operated paper cutting guillotines* published in 1988, ISBN 0 11 885460 7 and reprinted in 1992. HSE will continue, periodically, to review and revise this guidance.

Section 1 Machinery description

- hazards and safeguards

10 Guillotines consist of a knife, clamp, machine table and backgauge. The knife is driven through the paper stack onto a soft strip, the cutting stick, which is set into the bed of the machine table. Power can be applied to the clamp, backgauge and knife in a number of ways.

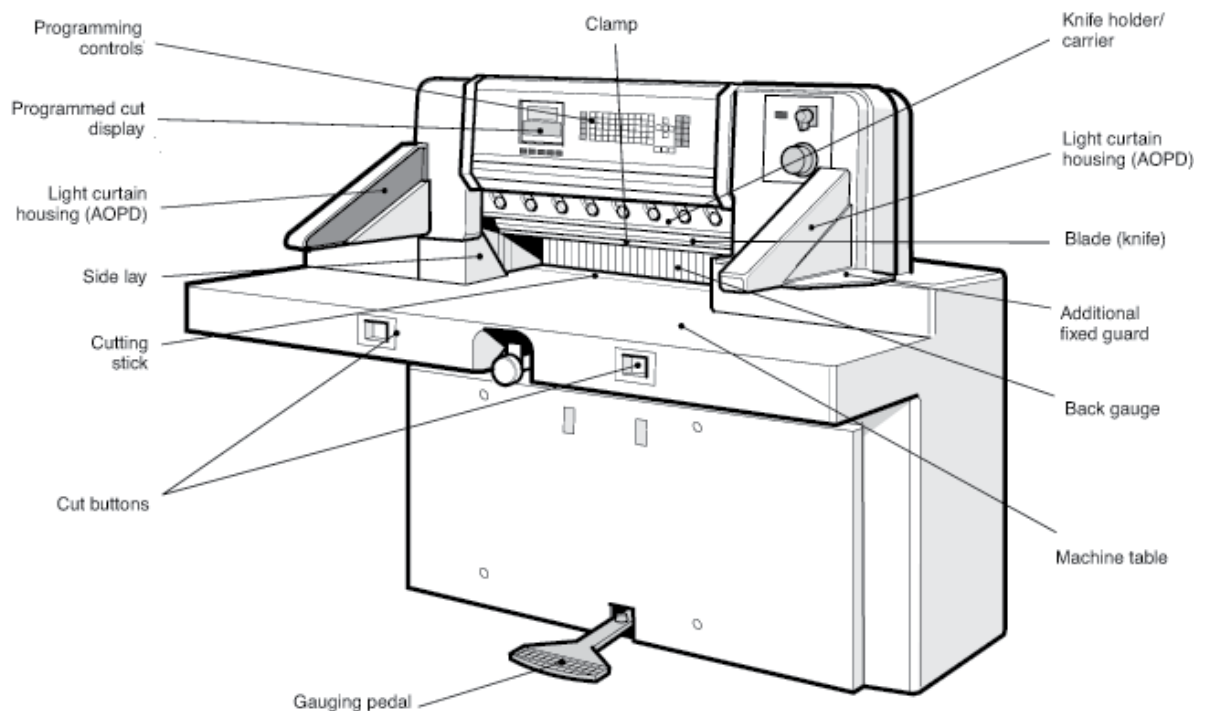

Figure 1 A typical guillotine with safeguarding by means of an active opto-electronic protective device (AOPD)

Hazards

Knife

11 Knives are normally driven at a reducing angle by:

- direct hydraulic power - the knife is driven down by the action of a hydraulic cylinder(s) and returns hydraulically or by springs. Control is by a hydraulic valve(s);
- direct hydromechanical power - a crank is driven by a hydraulic motor controlled by valves supplying oil to the hydraulic motor;
- clutch-operated mechanical power - the knife is powered from a continuously running flywheel via a crankshaft fitted with a friction clutch and brake. Knife control is by engagement/disengagement of the clutch and brake in turn;
- direct electromechanical power - the knife eccentric arm is driven directly by an electric motor and rotates once before actuating a switch to cut off power and applying the brake. Knife control is normally achieved by braking of the motor.

12 Contact with the knife edge when it is moving and when it is stationary can result in serious injury, including amputation. This can be caused, for example,

by inadequate guarding or failure of the knife to stop at the end of a stroke. Accidental contact with the knife edge is generally prevented by the position of the clamp which moves in advance of the knife, although part of the knife edge can be exposed at either side of the paper stack if the stroke is interrupted. However, injury can be caused by knives exposed during cleaning, changing and handling.

An operator suffered amputation of part of his thumb when the paper-cutting guillotine he was using overran. He was retrieving a cut stack and was injured when the blade failed to halt on the upstroke and descended part way. This was caused by a failure to maintain the brake, and a fault which occurred on the overrun detection switch. The solenoid-operated safety bolt for the knife carrier was also defective. The brake defect, overrun switch fault, and safety bolt were all rectified when the machine was subsequently serviced.

Clamp

13 The clamp holds the work in two stages:

- (a) gauging - alignment of the intended cutting line with the front edge of the clamp, normally achieved using a gauging pedal with direct mechanical linkage or a low pressure balanced hydraulic system;
- (b) cutting - this requires greater clamping forces which are achieved by variable hydraulic pressure, direct drive using a torque motor, or by manual operation of the clamp.

14 **Most injuries at paper-cutting guillotines are caused by clamp descent during gauging.** At this stage movement is often not safeguarded and the manual nature of the work may require the operator to handle work, such as business cards, near the clamp. To prevent crush injuries, the gauging force should be limited and maintained at values given in paragraph 108. Descent of the clamp under full power should be guarded.

A paper-cutting guillotine operator suffered a crushed finger when it was trapped between the clamp and table. The operator was gauging and placed a block of paper on the table. The backgauge was too far back, he leaned forward to pull work out, intending to adjust the backgauge, and accidentally depressed the foot pedal, operating the clamp. The gauging force was excessive and as a result the operator was off work for four weeks.

15 Lips on, or holes in, the clamp face should be avoided to prevent any shear traps between the ascending clamp and knife edge on the return stroke. Holes should be covered by plastic plugs, tape or similar means.

While cleaning the clamp face of a guillotine, an operator's foot slipped from the clamp pedal. The clamp returned upwards but his fingers were caught in the screw-adjustment holes. This caused amputation of part of the left index finger. Caps were subsequently provided over the screw-adjustment holes.

Machine table

16 Most machines have a solid, flat table although increasingly air tables are provided which reduce operator fatigue and can help to prevent manual-handling injuries by reducing frictional drag. Machines with opening tables, for example for waste removal, may present a crushing and entrapment hazard as the table closes. These should be effectively safeguarded by, for example, electrosensitive protective equipment (ESPE).

17 Handling systems such as pile hoists and jogging tables may also cause risk of injury if not safeguarded to prevent contact when in motion, see paragraphs 42-47 for further details.

Backgauge

18 The backgauge can be moved either manually or under powered operation to the correct position for paper cutting. Many machines may be programmed so that the backgauge automatically moves to the correct position for a sequence of cuts. The inclusion of a 'push out' or programmable ejection setting avoids the need for operators to reach beneath the cutting area and helps to reduce fatigue and upper-limb disorders.

19 Trapping hazards can arise between the travelling backgauge and the fixed rear side lays or retractable side lays used for rear loading. These should be safeguarded. The backgauge may move as soon as power to the machine is switched on. This should also be safeguarded by, for example, interlocking or positive command control systems. A trapping hazard between the backgauge and rear of the clamp can occur when the clamp plate is removed. Always ensure that the backgauge drive is disengaged before removing the clamp plate.

Drive machinery

20 Be aware of the risk of injury where there is exposed drive and transmission machinery, such as vee-belts and pulleys, chain and sprocket drives and intermeshing gear wheels, which may be accessed during maintenance and repair work.

Operation

21 Guillotines can operate in one of three ways:

- single stroke or manual operation where the controls have to be depressed to initiate each cut cycle;
- semi-automatic operation where the backgauge automatically moves to the next programmed position but the controls have to be operated before the clamp and knife movement can be initiated;
- fully automatic operation where programmed repeat strokes of the backgauge, clamp and knife are initiated by an initial single operation of the cut command controls.

Controls

22 Controls are provided on guillotines which:

- select the operating mode;
- set the backgauge position;
- operate the clamp for gauging;
- 'strike on' the clamp and knife;
- select knife change.

23 All controls should be within easy reach of the operator and their function should be clearly labelled by shape and colour, or by readily understood symbols.

24 Guillotine-mounted control devices should be in accordance with European Standard EN 60204: Part 1 1998. Foot-operated controls are only appropriate for gauging.

Two-hand control devices

25 At all machines it should only be possible to initiate a cut cycle, ie 'strike on', by operating a two-hand control which complies with EN 574: 1997 and EN 60204: Part 1 1998. This means that:

- two separate hand controls should be positioned and recessed so that it is not possible to span both with one hand only or to operate them with one hand and another part of the body;
- both controls should be operated within 0.5 seconds of each other before the machine will operate (exceptionally, on older machines, this may be up to 1 second). Where this time limit is exceeded both control devices should have to be released before operation can be re-initiated;
- if one control is released, both controls should have to be released and re-operated before the machine will operate;
- if one or both controls are released before completion of the stroke, the blade should either stop without delay or return to top dead centre.

26 Two-hand control devices alone are not an acceptable safeguard and must be supplemented by front and rear guarding as described in paragraphs 29-41.

27 In exceptional circumstances guillotines may be used with a single control device if high-integrity all enclosing interlocking guards are provided which are arranged with cross-monitored dual-channel control using two guard-position switches operating in opposite modes. A competent guillotine engineer should be able to advise whether this is the case.

Backgauge handwheel

28 If the backgauge can be moved manually by a handwheel and automatically under power, make sure that the handwheel either does not rotate during power drive or is of the solid type without spokes or projections. A gap of 25 mm should be maintained between the rear of the handwheel and the machine table.

Types of safeguard

Front guard

29 **Because in the majority of circumstances operators have to place their hands beneath the knife when positioning the work, a combination of a high-integrity method of safeguarding and a two-hand control device is needed. The various options are described in paragraphs 30-47.**

Active opto-electronic protective devices (AOPD) (photoelectric guards)

30 This equipment commonly projects a curtain of visible or infrared light across the front of the guillotine which if interrupted, for example by the operator's arm, will send a signal which stops or reverses the knife and clamp descent during the cutting cycle.

31 The AOPD machine control components such as solenoid valves and contactors, clutch and brake constitute the overall safeguarding system (electrosensitive protection device (ESPD)), see Figure 1, page 10. Operators rely not only on the correct functioning of the ESPD, but also on the performance of the brake, clutch and other control components so it is essential that they are all properly maintained.

32 Standards required at existing machines:

- the guillotine if supplied new between approximately 1974 and 1987 should have an ESPD designed and operating with full-function monitoring; see Appendices 5 and 6. This is the lowest standard acceptable for these older machines and some modifications such as the removal of the fully automatic facility may be necessary. A competent guillotine engineer or manufacturer/supplier should be able to advise;

- if first supplied after 1987, the safeguarding should meet the standards now detailed in IEC/EN 61496: Part 2 1997 and the publication HSG180,¹ (but see paragraph 5 of HSG180 for guillotines supplied between 1 January 1995 and March 1999 with respect to the need for risk assessment for upgrading work);
- if first supplied after 1 January 1995, the guillotine should be CE marked and meet the standards now detailed in IEC/EN 61496: Part 2 1997; EN 1010: 1999 and guidance within the publication HSG180,¹ (but see paragraph 5 of HSG180 for guillotines supplied between 1 January 1995 and March 1999 with respect to the need for risk assessment for upgrading work).

33 To provide sufficient protection to the operator, the position of the AOPD is critical. The minimum curtain separation distance depends on the stopping performance of the knife and the detection capability of the AOPD. Machines first supplied before the date of this publication should meet the standard detailed in Appendix 7. It should not be possible to reach over or under the curtain to the cutting stick from any direction, including the side of the machine table. The position of the AOPD for several typical formats is shown in Figures 2-6. Note that more recent guillotines manufactured in accordance with pr EN 1010 may have reduced distances for the AOPD position:

- where the AOPD extends down to the machine table and there is fixed side guarding, the outermost (lowest) front beam should be at least 460 mm from the cutting stick and less than 38 mm from the table (see Figure 2);

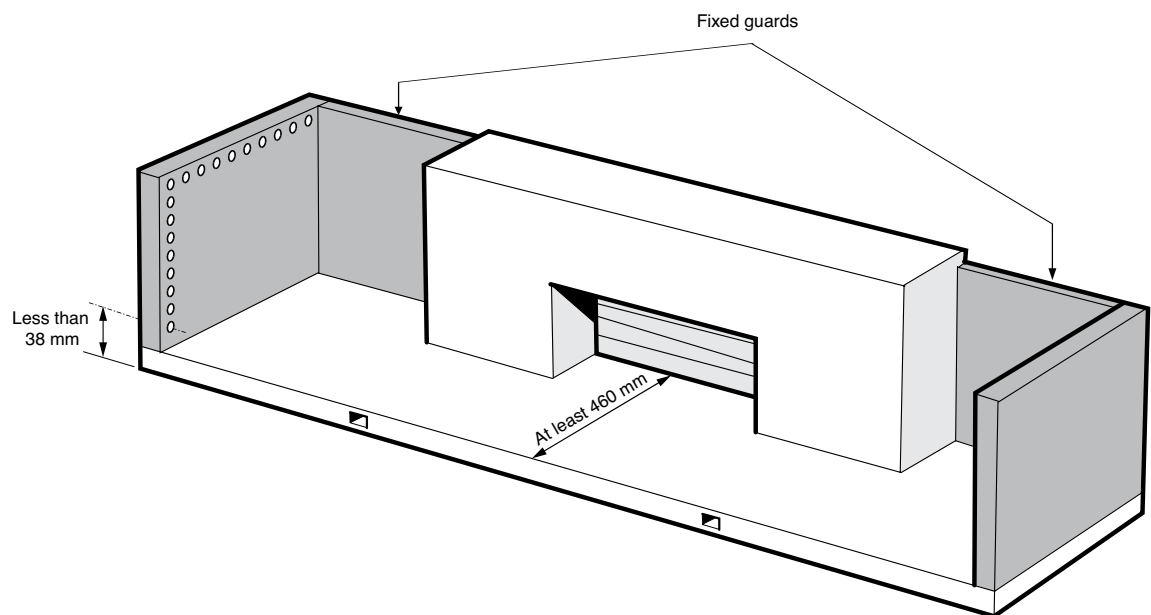

Figure 2 Photoelectronic curtain (AOPD) extending to machine table in combination with fixed guards

- where clearance is not required under the AOPD housings, the housings should either extend to the machine table or have fixed guards fitted beneath them. In this format, the outermost beam should be positioned at the table edge at a vertical distance of no more than 175 mm and at a horizontal distance of at least 635 mm from the cutting stick (see Figure 3);

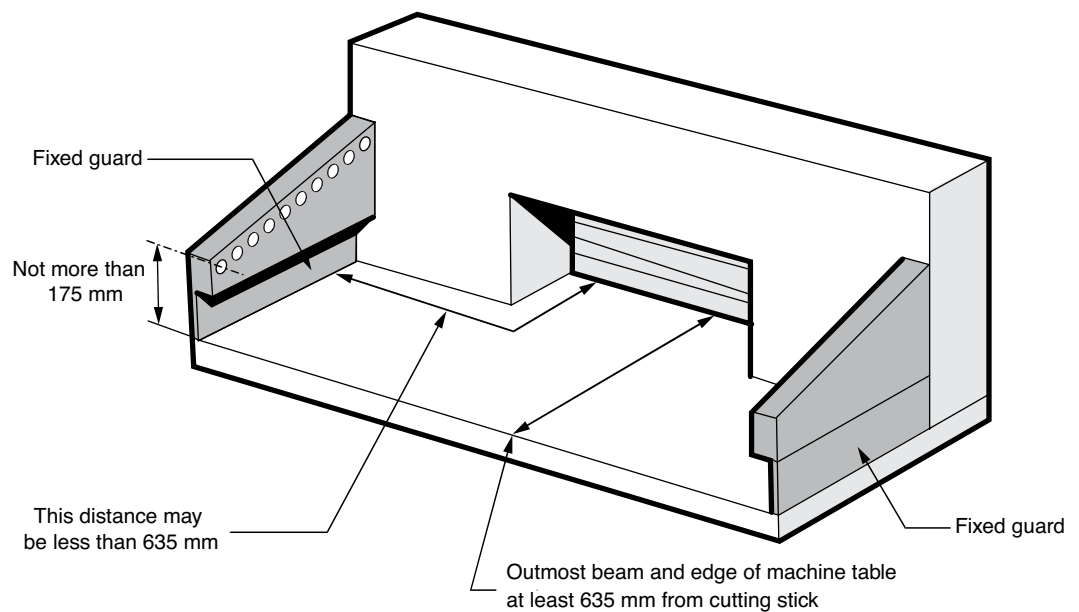

Figure 3 Use of fixed guards where clearance is not required beneath the AOPD housings

- where clearance is required beneath the curtain housing, the outermost beam should normally be located between 610 mm and 635 mm from the cutting stick and no more than 185 mm above the table. The housings should either be positioned at least 610 mm from the point where the cutting stick meets the side lays (Figure 4), or extensions to the machine table should be provided to increase the distance between the table edge and knife to 850 mm (see Figure 5);
- exceptionally, some newer very large format machines with a useable pile height greater than 185 mm may have the outermost beam located between 610 mm and 700 mm from the cutting stick and no more than 205 mm above the table. An additional beam must be provided between 400 mm and 550 mm from the cutting stick and between 0 mm and 205 mm above the table (see Figure 6);

An operator had both hands amputated above the wrist when using a guillotine to cut slips of card for a wallpaper sample book. The guillotine was being used in fully automatic mode. It was found to be possible to reach the cut area beneath the lowest part of the AOPD without interrupting it.

- similarly, guillotines with an automatic cutting sequence must also have been provided with an additional beam between 400 mm and 550 mm from the cutting stick and between 0 mm and 205 mm from the machine table (see Figure 6).

An operator was using a guillotine on the automatic setting for cutting labels. The machine had been modified for import into this country and a spacer had been added to bring the AOPD housing further from the blade. This enabled a tall person to approach the blade without breaking the curtain. The operator amputated the tip of the middle left-hand finger when adjusting the position of a timber weight on the paper stack without breaking the curtain.

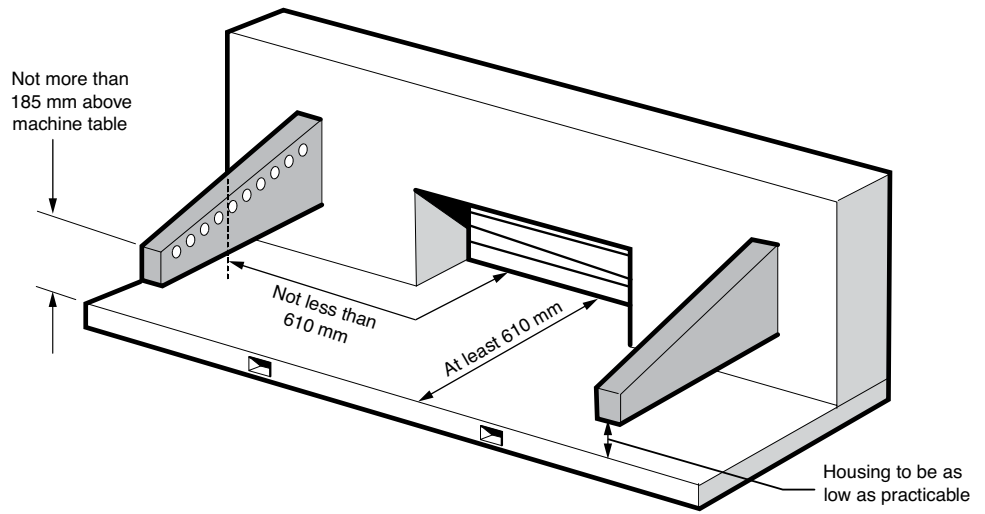

Figure 4 Position of AOPD housings and outermost beam where clearance is required beneath the housings

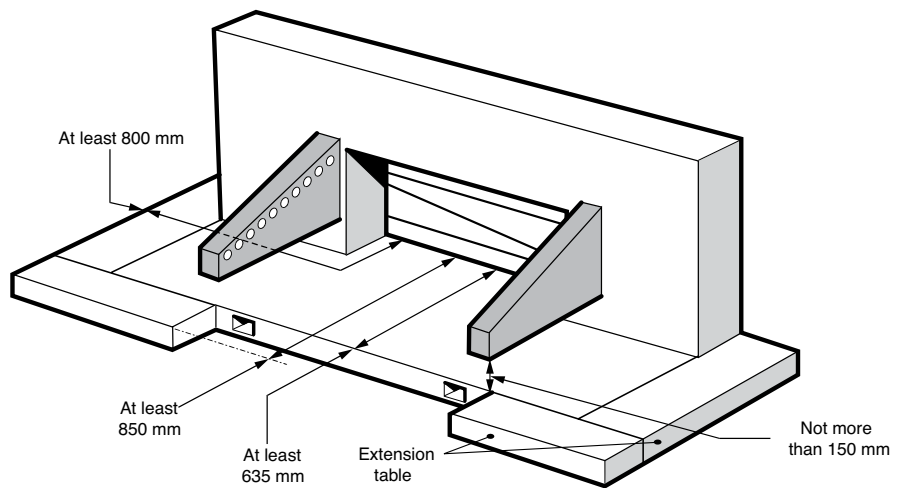

Figure 5 Use of extensions to the machine table where clearance is required beneath AOPD housings

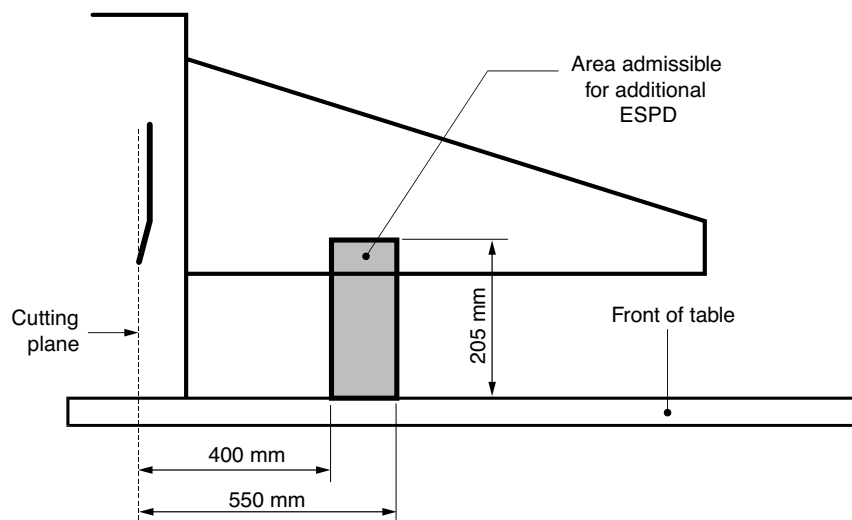

Figure 6 Position of additional beam for large format machines

Interlocking guards

34 Interlocking guards prevent access to the clamp and blade area when closed. Correctly functioning interlocking guards should operate so that:

- when in the closed position, it is not possible to reach under, over or around the sides of the guard;
- striking on is only possible by operation of synchronous two-hand controls with the guard closed (see paragraphs 25-27);
- when opened, the interlock prevents powered operation of the knife and clamp. This is normally by means of two separate cam-operated safety position switches set to operate in opposing modes. In other words, if one switch fails, the guillotine will not operate;
- if an attempt is made to open the guard during a stroke, the clamp and knife should either retract or stop, or the guard should be locked in the closed position until the stroke is completed, see Figure 7.

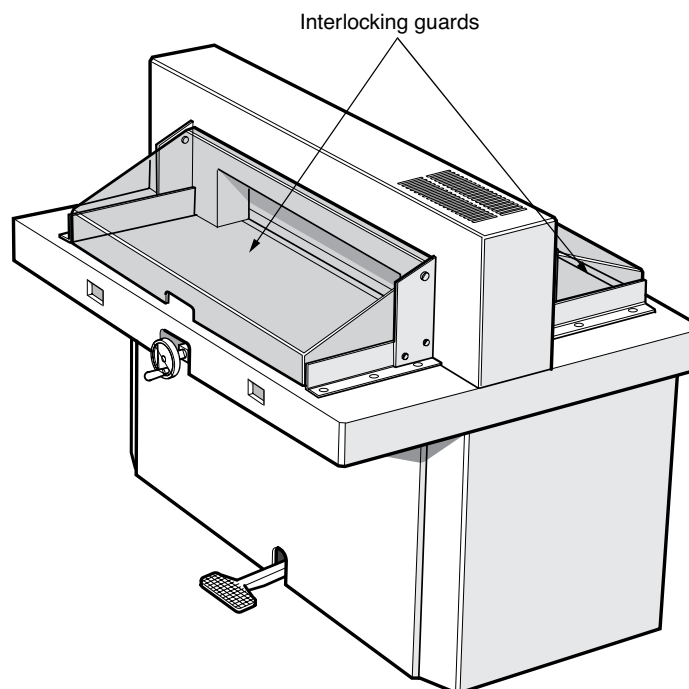

Figure 7 Guillotine with an interlocking guard

Falling finger guards

35 Very old machines were sometimes provided with a system of interlocked falling finger guards. Each finger was mounted on an interlocked steel bar and individually hinged outwards so that they would take up the profile of the work. This arrangement does not provide sufficient protection and should be replaced by an enclosing interlocked guard or equally effective means. **From the date of this publication it is no longer acceptable for machinery to be guarded in this way.**

Automatic sweepaway guards

36 Automatic sweepaway guards found on certain older machines are designed to push the operator's hand away from the danger area as the clamp and knife descend, see Figure 8. They are not acceptable on new machines under any circumstances. **From the date of publication of this book, guillotines with automatic sweepaway guards new or second hand should not be supplied or sold on in the UK.**

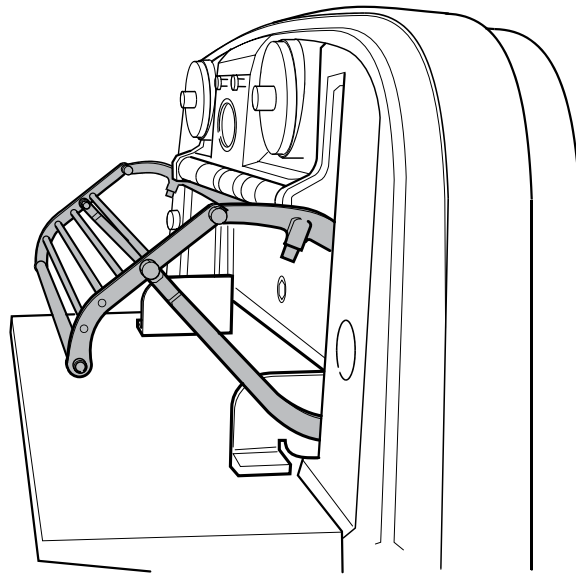

Figure 8 Guillotine with sweepaway guard in extended position.
Note: side guards omitted for clarity

The operator of a 32 inch (813 mm) paper-cutting guillotine fitted with a sweepaway guard and two-handed control was seriously injured when the blade repeat cycled and amputated eight fingers and one thumb. The bolt releasing mechanism was not properly adjusted and the bolt was not interlocked.

An operator was removing paper after completing a cut when the knife descended and amputated the tip of his left-hand middle finger. The machine was fitted with a sweepaway guard which extended to 15 inches (381 mm) and two-hand controls. It was concluded that the knife descended under gravity due to brake failure. The hydraulic clamp actuated the sweepaway device but there was no direct interlocking between the knife and the sweepaway device.

An operator lost the tips of two fingers when using a 1970 guillotine fitted with a sweepaway guard. The brake attached to the motor driving the movement of the blade did not operate due to a loose retaining bolt which had become loose and jammed the brake open, allowing continued downward movement of the blade from top-dead-centre. There had been no preventative maintenance for the machine which had been consistently overrunning top-dead-centre.

37 Where existing machines are still in use, it is essential that the correct extension of the device, clutch and brake performance are maintained, see Figure 9. Machines should be upgraded in accordance with the following checklist so that:

- the main guard bar moves forward at least 500 mm from the front of the clamp;
- the guard is in its fully extended position by the time the clamp has descended 50 mm from its top position, unless the guard operates on knife movement in which case either the guard is fully extended when the knife has descended 50 mm and the clamp precedes the knife by less than 14 mm, or the gauging pedal is interlocked so that it has to be fully depressed before the knife can move;
- the movement of the guard bar is as near horizontal as possible;

- the maximum height of the guard bar above the table is not greater than 180 mm at the lowest point of sweep;
- the guard bar is at least as long as the clamp;
- additional guard bars at centres not greater than 100 mm (see Figure 9) have been provided to prevent access over/through the guard using robust material which has not weakened the main bar by the means of fixing (eg welding);
- side access to the danger zone is prevented when the guard is extended by means of side tables or fixed guards manufactured to the dimensions shown in Figure 9;
- where means have been provided to disconnect the sweepaway guard linkage during knife change, unguarded operation of the knife and clamp is prevented by interlocking the guard with the two-hand control and clutch, for example by monitoring the rotational movement of the guard crank shaft;
- the integrity of the electrical control system meets IEC/EN 61496: 1997. This may necessitate complete renewal of the electrical control system;
- the control cams and associated switches are arranged to prevent single component failure giving rise to danger. This can be achieved with a dual-channel system with one positively and one negatively operating limit switch;
- two-hand controls are fitted which meet the standards detailed in EN 574: 1997.

38 If as a user you have any doubts about these points, contact the competent guillotine engineer who carries out your six-monthly inspections and tests.

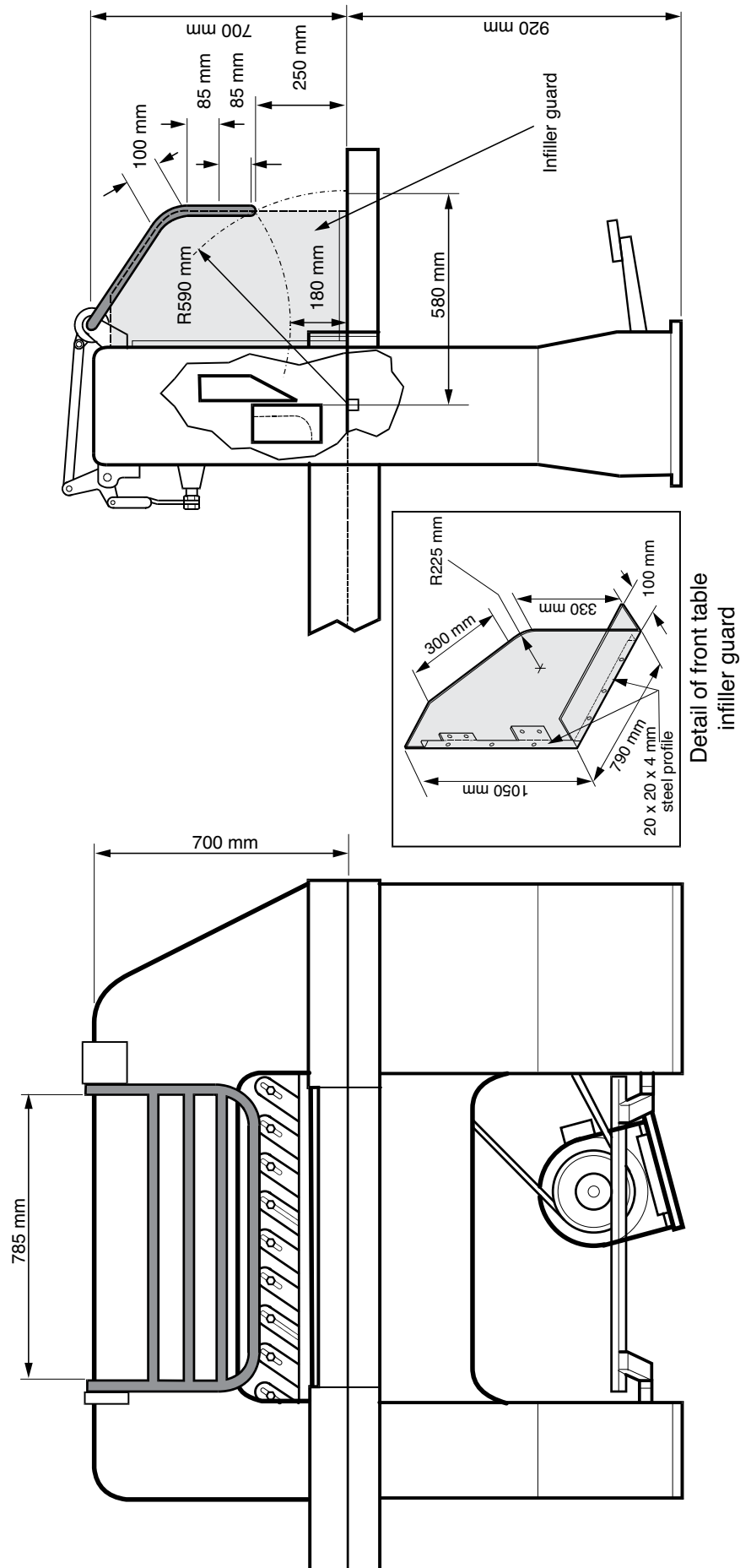

Figure 9 Recommended specification for additional guarding to Johne Perfecta guillotines provided with a sweepaway device

Body-push guards

39 These devices are no longer an acceptable means to safeguard guillotines and machines provided with them should already have been withdrawn from service. Prosecution may result from the operation of guillotines with this type of device.

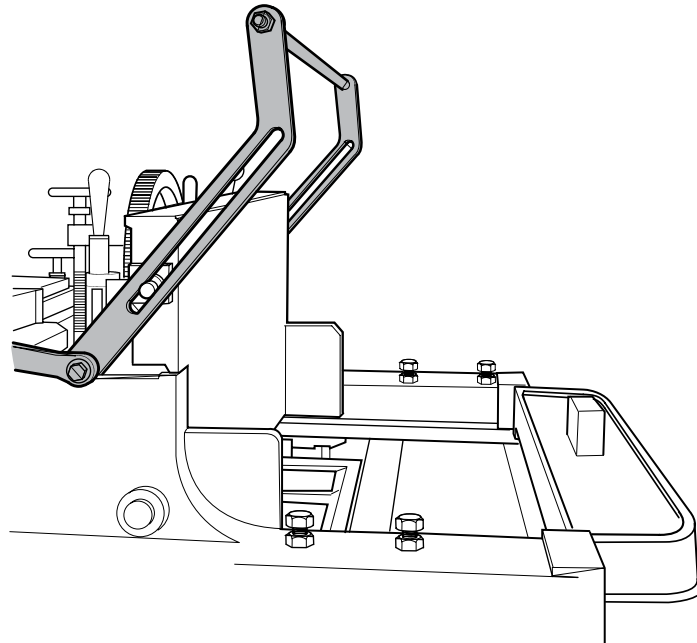

Figure 10 Guillotine provided with a body push device in extended position. These machines should no longer be in use

Rear guards

40 Safeguarding should be provided to prevent access to the rear of the clamp, backgauge and knife. This is normally achieved by a system of fixed barriers with an interlocked access gate or fixed or interlocked tunnel guards attached to the rear of the machine table. BS EN 294: 1992 provides guidance on reach distances. Access to the rear of the knife and clamp cannot be safeguarded simply by position, ie against the wall.

41 Rear safeguarding should be installed so that:

- fixed guards do not hinder knife changing and lubrication;
- when interlocked rear guards or gates are opened, powered operation of the knife and clamp is prevented;
- where there are traps between the moving backgauge and other fixed parts, including the open guard, the guard is interlocked with power to the backgauge motor;
- where back feeding is necessary in the case of very large work or automated paper handling, fixed, interlocked guards or ESPEs are provided. These should also prevent access to any automatic clamping arrangements and be positioned so that traps are not formed by the movement of the backgauge or powered side lays;
- where ESPEs are fitted, they are of the same integrity as those for front guards and the lowest and outermost beams are not more than 38 mm above the rear side lays, and are at least 635 mm from the nearest trapping point.

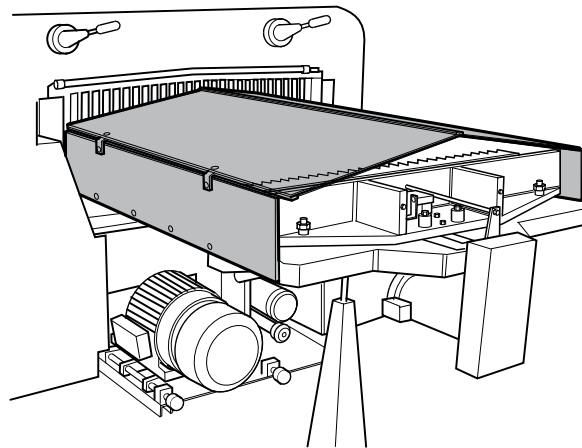

Figure 11 Fixed guarding at rear of guillotine

Safeguarding of ancillary handling equipment

42 A large number of manual handling injuries occur to operators of powered guillotines every year. A suitable and sufficient manual handling assessment made in accordance with the Manual Handling Regulations 1992² will identify any need for mechanical handling aids such as pile lift/hoists, scissor lifts, jiggers, stackers and turning units. The use of this equipment is encouraged by PIAC.

43 Such equipment will also need to be properly safeguarded and maintained. Lifting equipment, which will include pile hoists and scissor lifts, should be subject to thorough examination as part of an examination scheme in accordance with the Lifting Operations and Lifting Equipment Regulations 1998.³

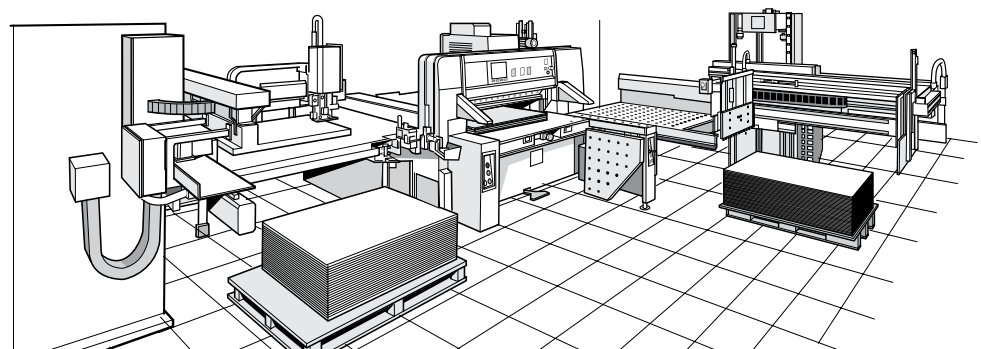
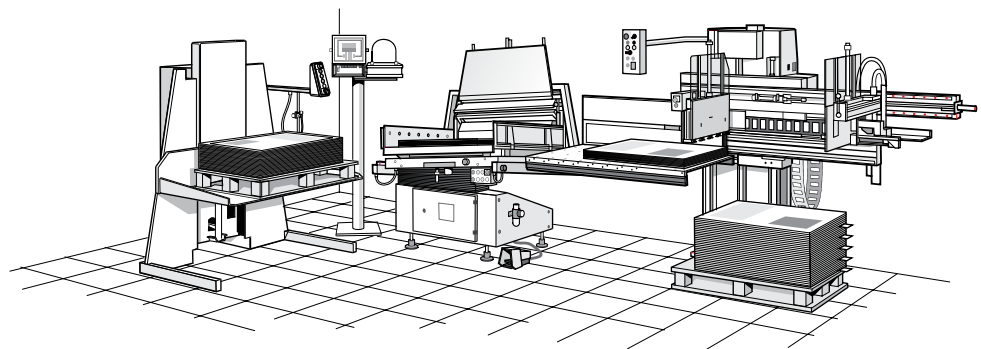

Figure 12 Various handling equipment including pile hoist, jigger and de-stacker/re-stacker

Pile/lift/hoist

44 Where fitted, this equipment should be installed so that:

- additional pile lifts and hoists sited at the side of a guillotine are provided with hand protection between the lift/hoist and the guillotine, normally in the form of a fixed plate to the front or side;
- safe working loads are clearly marked;
- the hazardous zone is marked on the floor by means of yellow and black hatching to extend at least 300 mm beyond the danger area.

Scissor lifts

45 Scissor lifts should have been designed and manufactured in accordance with BS 5323: 1980 and installed so that:

- the safe working load has been marked;
- traps between scissor arms had been prevented by suitable flexible guards;
- sensitive edges or trip flaps had been fitted to the underside of the platform where shear traps are created. Check these regularly;
- a suitable mechanical scotch is provided where access beneath the raised platform is required.

Joggers and auto-stacking tables

46 This equipment should have been installed so that:

- hand plates have been provided when sited next to the side of the guillotine;
- where air presser rollers are fitted, an AOPD (type 2) is fitted to the front of the table together with sensors on the roller mechanism to halt forward movement on interruption;
- access to the rear of the equipment is prevented, for example by fixed or interlocking guarding;
- joggers are firmly fixed to the floor with suitable foundation fixings or where mobile by design, means are provided to maintain a minimum separation distance between the guillotine and adjacent equipment.

De-stackers and re-stackers and turning units

47 This equipment should be installed so that:

- there are 'all enclosing' 1800 mm high fixed barriers which if access is required are provided with access gates that are electrically interlocked with the operating circuits of both the guillotine and the handling equipment;
- exposed stacking points, where access is possible, have AOPD (type 2) protection;
- ascending and descending tables have protection at the base by means of trip devices or pressure-sensitive strips where there is a risk of entrapment;
- stack lift unloading and loading systems have the hazardous zone on the floor below the lifting/lowering area marked with yellow and black hatching to extend at least 300 mm beyond the loading/unloading pallet area;
- the pallet guide plate is firmly fixed to the floor.

Section 2 User requirements

Introduction to section

48 As a user of a guillotine, you need to make sure that you comply with a number of legal requirements. These are summarised in the box insert. The information within this section will provide you with the practical guidance needed to ensure compliance is achieved.

The **Supply of Machinery (Safety) Regulations 1992** impose duties on manufacturers, suppliers and importers of new and substantially refurbished machinery and are intended to provide protection for users. They became compulsory as from 1 January 1995. See *Buying new machinery*⁴ for further advice.

The **Management of Health and Safety at Work Regulations 1992**⁵ include duties to ensure that:

- a risk assessment is made which identifies all hazards and the risk of harm associated with the use of a guillotine and ancillary equipment, including dangerous parts and tasks such as knife changing;
- control measures, such as ESPes and safe working procedures, are put into place to make sure personnel are not harmed;
- employees are given training and instruction in the use of guillotines and ancillary equipment;
- control measures which include safeguarding and training are properly implemented and maintained.

The requirements of the **Provision and Use of Work Equipment Regulations 1998 (PUWER 98)**⁶ include duties to ensure that:

- dangerous parts of guillotines and handling equipment are safeguarded;
- controls and control systems are unambiguous, reliable and perform all the tasks necessary for safe operation,
- eg provision of emergency stop and other controls;
- guillotines are maintained. This means performing the daily checks described in this section (and recording the results in a maintenance record or log, where provided);
- guillotines are inspected by a competent person at suitable intervals (detailed later in this section);
- maintenance and inspection can be carried out safely,
- eg adequate working space at electrical cabinets;
- equipment can be isolated from the electrical supply.
- A properly earthed electrical supply isolator should be provided by users adjacent to the machine;
- records of inspections are kept. See Appendix 2 for details of a sample maintenance record/log;
- equipment sold on is accompanied by the maintenance record/log;
- new equipment (including second-hand equipment from outside the European Economic Area (EEA)) conforms with product safety legislation, eg Supply of Machinery (Safety) Regulations 1992;
- full instruction and training is given to operators.

Maintenance and inspection records - Logs

49 To help you comply with the requirements of PUWER 98, sample forms for recording the results of in-house daily and monthly checks and a sample log have been included in Appendices 2 and 3. The log contains sections for recording:

- name and address of manufacturer/agent;
- machine model and type including serial no;
- name and address of user;
- results of commissioning examinations and tests (see paragraph 61);
- technical details of all mechanical and electrical modifications,
- the date undertaken and by who;
- all reports by competent engineers/surveyors;
- details of servicing undertaken;
- date sold and to who;
- names and addresses of subsequent suppliers and users;
- technical details of safety-related parts of the control system in the form of diagrams, schematic drawings, etc;
- all available details of programmable electronic-based items such as software listings/versions.

50 It is strongly recommended that you keep such a log for existing machines. The guillotine log provides you, the enforcing authority, your insurance company, inspecting organisations, engineers and prospective purchasers with evidence that the guillotine has been properly maintained. By making sure you keep it up to date with the above information, it will demonstrate that daily, monthly and six-monthly inspections and tests have been carried out and that any manufacturer's safety modifications have been implemented. **Remember, you are legally required to keep records of inspection.**

51 The information within a log can be essential for continued safe operation of the guillotine. This information should come with the machine regardless of whether new or second hand. Query any machine that comes without this paperwork.

Buying a guillotine

52 Before you make a purchase, tell the supplier where the machine will be used.

53 Ask the supplier the following questions:

- To what standards is the guillotine manufactured?
- What safeguarding system is provided?
- What has been done to eliminate the risk of electric shock particularly during maintenance work when covers or control panel doors may be open?
- Are there possible risks from other sources of energy, such as hydraulic or pneumatic?
- Will you supply me with a current log (or the information to complete one) and machine instruction manual including information on installation, maintenance, cleaning, and breakdown procedures?
- Will you provide or arrange for the first six-monthly inspection?

54 It is good practice for the supplier or manufacturer to have service back-up or a help line. You might check what is in place before you buy.

55 On buying the guillotine make sure that:

- an up-to-date, complete machine log and instruction manual is provided;
- unless it is a second-hand machine which was first supplied before 1 January 1995, it has a CE mark affixed and a copy of the EC Declaration of Conformity has been provided;
- the supplier has explained what the machinery is designed to be used for and what it cannot be used for;
- an instruction manual has been supplied which includes instructions for cleaning, knife changing, assembly, installation, commissioning, adjustment and maintenance;
- the instruction manual is clearly understandable and legible;
- information has been provided about any remaining risks from the machine, and the precautions you need to take to deal with them, eg recommended safe systems of work. These may include electrical, hydraulic, pneumatic or thermal hazards;
- any warning signs are visible and easy to understand;
- during commissioning comprehensive training is given;
- you think the machine is safe;
- any early concerns about the safety of the machine are reported to the supplier.

56 Never assume that machinery is safe just because it has CE marking. You need to carry out a risk assessment in accordance with the Management of Health and Safety at Work Regulations 1992 and check that the machine is safeguarded properly as required by the Supply of Machinery (Safety) Regulations 1992 and PUWER 98. The leaflet *5 steps to risk assessment* provides general advice.⁷

Upgrading guillotines

57 Guillotines currently in use may require upgrading to meet the standards detailed in this book and a competent engineer may advise you of this at the time of the six-monthly inspection referred to in paragraph 94. It is essential that these modifications are only undertaken by competent guillotine engineers. Guillotine control systems and protective devices are sophisticated systems and accidents can result if they are tampered with by people with insufficient knowledge or understanding of the machine. Guidance on competence is given in Section 3 of this publication.

58 Guillotine users have a responsibility to ensure that the manufacturer's/supplier's instruction manual and log (where provided) are kept available, both for the use of operators and for those undertaking routine maintenance. Such manuals and logs should accompany the machine throughout its working life.

Locating and siting machines

59 Careful consideration should be given to the position chosen to site a guillotine. Operators need sufficient working space to allow safe operation and use of the guillotine controls and associated equipment such as pile hoists and jogging tables. Congested work areas can create additional trapping and slip/trip hazards. Make sure you:

- allow sufficient space to ensure efficient throughput of work;
- plan for the expected quantity of work in progress and define such areas by cross hatched lines marked on the floor;
- position machines away from main thoroughfares.

60 Remember that access will be required for maintenance and cleaning at the rear and sides of the machine. Where practicable the distance around the machine should be at least 0.5 m. For example, where access to electrical systems is required and live conductors are within reach, the working space dimensions should be adequate to allow people to pull back away from conductors without risk, and if people need to pass one another, to do so with ease and without risk. As a guide, the distance between live parts and a fixed obstruction such as a wall should not be less than 1 m.

61 When a machine is moved to a new location, whether in the same building or elsewhere, it should be inspected and tested by a competent guillotine engineer after re-installation as per the six-monthly inspection.

Commissioning inspections and tests

62 Following the installation of a new or second-hand machine, an inspection and any necessary tests should be carried out by a competent guillotine engineer who has access to all the manufacturer's/supplier's information relating to the machine. Ask the engineer if he has included the following items when carrying out the inspection:

- the front and rear table guards comply with the guidance in this book;
- any brakes and clutches are adjusted to the manufacturer's specification;
- the stopping performance is correct and the overrun detection systems are correctly set.

63 In addition, where the guillotine has ESPE, ask the following:

- What is the mean overall stopping performance of ten readings?
- What is the minimum object detection capability of the AOPD?
- What is the distance from the cutting stick to the nearest part of the AOPD?

64 Ensure that these measurements are checked for compliance with those provided by the manufacturer and that adjustments are made as necessary.

65 When a machine is re-installed at a new location within your premises, an inspection and test should be carried out as for the six-monthly inspection. It is strongly recommended that you do not accept a machine unless the results of these tests have been recorded in a machine log and that these have in turn been signed by the supplier/engineer.

66 Be aware that manufacturers and suppliers of both new and second-hand machines should ensure that appropriate testing is carried out on their products so that the standards described in Sections 1, 4 and 5 of this publication are met. Make sure you are given relevant information about such tests so that the guillotine can be properly used and maintained.

Instruction manuals

67 The following information should be provided in the form of a clearly written instruction manual:

- the installation procedures;
- the purpose and operation of the controls;

- the correct methods of operation and maintenance;
- restrictions on use in certain environments, eg potentially flammable atmospheres.

68 Full details of the contents of these manuals is given in Appendix 1.

Training and safe working practices

69 Make sure all guillotine operators are competent. They should have been trained to understand:

- risks arising from the use of the machine including specific operations such as knife changing and knife cleaning, etc;
- the operation of controls and safeguards;
- the importance of safe working practices;
- how to carry out daily checks on the machine.

70 For general advice on training staff, see the PIAC open learning package.⁸ Printing colleges, safety training organisations and guillotine suppliers can often provide formal short courses. Guillotine operators should receive training on the aspects detailed in paragraphs 71-93 and 101. Remember that the Employment of Young Persons (Safety) Regulations 1979⁹ requires specific risk assessment to take account of the additional risk arising from the inexperience and immaturity of a young person.

Startup procedure

71 On completion of the daily checks detailed in paragraphs 85-90, if the machine is in good working order operators should sign the log. Operators should report any machine that fails to meet the performance standard to the management who should then lock off and label the machine until the fault has been investigated and remedied.

72 Operators should not operate a machine with a significant defect. Details of any defect or abnormal event should be recorded in the log, for example failure of the operation of the AOPD or unprovoked lock out.

73 Operators should also check that the knife does not protrude below the bottom of the clamp when it returns to top-dead-centre on completion of a trial stroke.

Gauging

74 Operators should be trained to use the following procedures when gauging:

- always check that thumbs and fingers are clear before bringing the clamp down;
- where fitted, use the optical cutting line indicator to check that it is safe to depress the gauging pedal;
- expel air from the pile only by a single operation of the clamp, not by repeated use of the clamp, hands, or blocks of wood. To remove air, provide jogging tables or a programmed clamp/no-cut facility.

Knife cleaning

75 Certain operations will lead to the regular need to clean the knife with solvent, for example where cutting of labels leads to a build up of adhesive.

76 Operators should use a safe system of work as recommended by the manufacturer. If no recommended system is available you should:

- either manually (with the power supply isolated) or in knife change mode, move the knife to bottom-dead-centre so that it is in contact with the cutting stick;
- using a holder containing the solvent soaked cloth, wipe the knife. Do not hold the cleaning cloth directly in your hand;
- clean each side of the knife from the respective side of the machine - avoid reaching beneath the blade and upwards.

Knife changing

77 Knife changing is a particularly hazardous operation and special precautions are required to prevent injury. Always stress the dangers to those performing the work. **Only trained competent and authorised personnel should undertake this task.**

An operator suffered a severe cut when a new guillotine blade he was installing fell onto his foot. He had removed the new blade from its case and placed it onto a table to insert the carrying handles. As he did this the blade slipped and fell. The operator had failed to clear the table of other material or to allow sufficient working space for this task to be undertaken safely.

78 Where provided you should follow the manufacturer's instructions. If no instructions are available you should develop, in conjunction with a competent engineer, a safe system of work. This will depend on the make of machine but should include the following principles. Make sure:

- the procedure takes account of the fact that the AOPD may not be active on older guillotines during the knife-change operation;
- the area is clear of pallets and stored materials;
- every knife has its own case/box (ie one for both the new and old knives);
- that both the knife cases/boxes and holder are maintained in good condition so that the blade edge is properly protected and the knife can be held securely;
- there is a secure, clear surface to put the knife case/box on - normally the machine table;
- you remove the side lays where this will assist in knife removal;
- that the knife does not overhang the edge of the table;
- you have all the correct tools including the knife holder;
- other persons are excluded from the knife-change area by signs and barriers (unless the large size of the knife requires two to carry it. In these circumstances, it may be possible to slide the knife onto an adjacent table at the same height without having to lift it);
- the knife is exposed for the least possible time;
- knives are not rested or placed on paper stacks;
- the movement of the knife is limited to the shortest distance possible;
- the cutting stick is replaced when the knife is out;
- a 'daily check' takes place after a knife change.

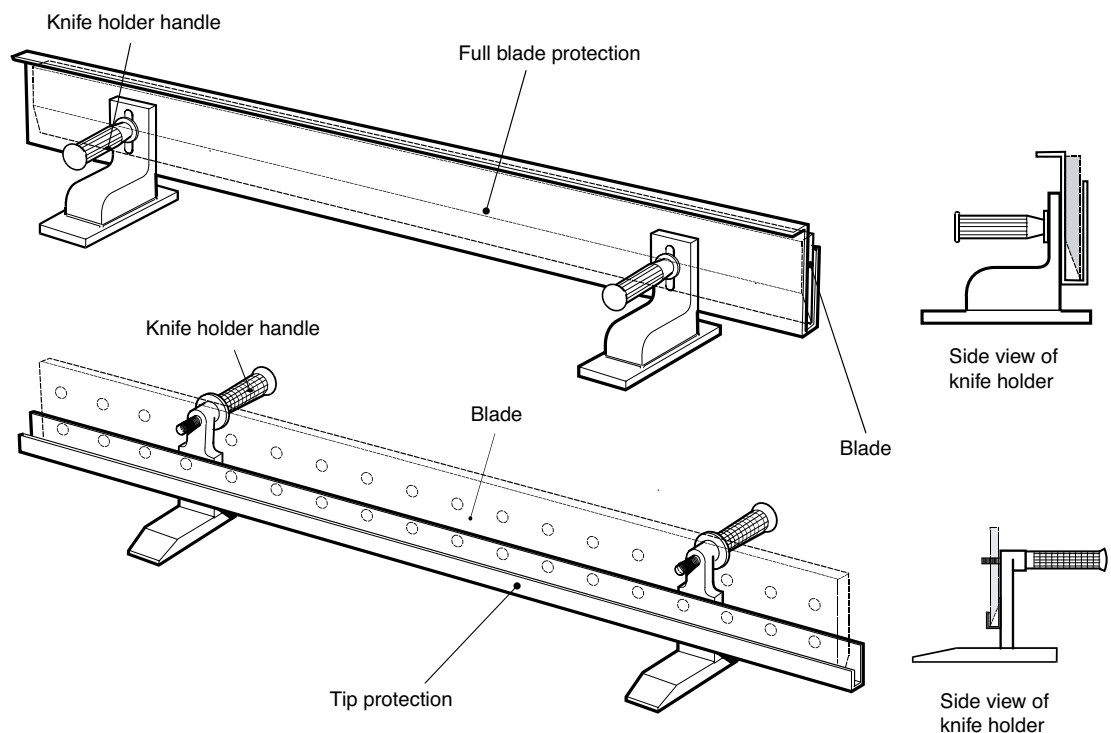

Figure 13 Two types of knife holder

79 There are two types of knife for cutting paper for print work: steel or tungsten carbide. The latter may give a life increase between 10 and 25 times - with less need for sharpening and changing. Always use a good quality knife. Do not use a blunt knife for prolonged periods as this can cause the knife to shatter, damage the machine and produce poor quality work. A reputable supplier for regrinding knives should be used who will give you advance warning should there be a problem with the knife, eg bowing, wear or over-grinding/end-of-knife life.

Routine maintenance, inspection and testing

80 Various safeguarding equipment may be used to protect guillotine operators from risk of injury, and it is essential that these are maintained in working order and checked to ensure proper functioning.

81 All guillotines should be subject to daily and monthly checks and six-monthly inspections as summarised in Table 1. The same checks should also take place after knife changing.

| Guillotine safety device | Daily shift check | After knife change | Monthly maintenance check | Six-monthly inspections |
|--------------------------|-------------------|--------------------|---------------------------|---|
| Interlocking | Operator | Operator | Operator | Guillotine engineer/ engineer surveyor |
| Photoelectric | Operator | Operator | Not applicable | Guillotine engineer/ engineer surveyor |
| Sweepaway | Operator | Operator | Operator | Guillotine engineer/ engineer surveyor |

Table 1 Summary of who should carry out the checks and inspections appropriate for different safeguard arrangements and at what frequency

82 You can record the results of every check and inspection using the sample forms given in Appendix 2. Carry out daily or monthly checks using trained, competent operators and ensure that managers monitor that the checks take place. The checklist has a place for managers to sign to confirm this. If the guillotine fails any part of the check or test, report this to management who should immediately take it out of service and have it inspected by a competent guillotine engineer.

83 Six-monthly inspections of guillotines, including all safety components (eg brakes, clutches, interlocks, switches and cams), stopping performance and gauging pressure need to be carried out by a competent guillotine engineer/engineer surveyor. Routine servicing and maintenance work may be carried out at the same time.

In-house daily/shift/after-knife-change maintenance checks

84 The following series of maintenance checks should be carried out by a competent operator:

All machines with two-hand control

85 The guillotine should strike on when you operate both controls independently within 0.5 seconds.

86 The guillotine should not strike on when you:

- operate each control and reset it in turn;
- operate one control followed by the other after a short delay of 2-3 seconds;
- repeat the last test with operation of controls in reverse order;
- operate both controls within 0.5 seconds but release one mid-way through the stroke and then re-operate it;
- repeat the last test but release the other control.

ESPEs

87 With the power on but the guillotine at rest:

- check AOPD status lights;
- insert the manufacturer's recommended test piece into the curtain and pass it slowly down the curtain with the test piece directed towards the cutting stick at three positions - at either side adjacent to each housing and in the centre. The test light should illuminate whenever the curtain is interrupted;
- where AOPD status lights are not fitted, perform the above test while a second person makes repeated attempts to strike on. No movement of the knife or clamp should occur while the test piece is interrupting the curtain;
- initiate a stroke and move body forward to interrupt the curtain while keeping your hands on the two-hand control. The knife and clamp should come to rest or reverse without any delay. **Do not attempt to thrust arm through the AOPD guard towards the blade;**
- check the operation of the two-hand control in accordance with paragraphs 85 and 86.

Interlocking guards

88 Where there is an automatic locking arrangement:

- strike on and apply a light upward force to check that the guard does not open.

89 Where there is no locking arrangement:

- check the stopping efficiency of the knife by opening the guard at mid-stroke of the knife first, and then the clamp. Each should come to rest without any apparent delay.

90 Where there is a single-control device and the interlocking guard has to be held closed against spring pressure to initiate a stroke:

- operate control and then close guard. The guillotine should not strike on;
- release the control and re-operate with the guard closed. The guillotine should strike on;
- with the guard still closed, operate the control but release the guard before the knife reaches bottom-dead-centre. The knife motion should cease or reverse.

Monthly/after-knife-change maintenance checks

Sweepaway guards

91 Check that:

- the main guard bar extends at least 500 mm by the time the knife or clamp has descended 50 mm and that the guard bar is no more than 180 mm from the table at the lowest point of sweep;
- the operation of the two-hand control is in accordance with paragraphs 85 and 86.

92 Inspect the guard linkages for wear at pivot points, pins and mountings.

Interlocking guards

93 Check that:

- interlocking devices such as valves and electrical switches are securely attached;

- actuators such as cams, levers and linkages are correctly aligned and attached. These should be non-adjustable, for example by using pins and dowels, instead of grub screws;
- there is no lateral movement of the guard which would cause the interlocking devices to become mis-aligned;
- any wear in the interlock and actuator does not allow knife or clamp operation when the guard is partly open;
- check the operation of the two-hand control in accordance with paragraphs 85 and 86.

Six-monthly inspection and check

94 Every six months a competent guillotine engineer or independent engineer/engineer surveyor should perform a thorough inspection of the machine which should comprise a series of performance checks and tests **in addition** to the various checks and tests carried out at each shift, after knife changes and every month. These are detailed in Section 3 of this publication. A written report should be issued and kept in your log (see Appendix 2).

Engineer's competence guide

95 Before employing a service company or engineer, satisfy yourself of their competence. You can do this by asking the following questions. This list is not exhaustive and you need to assess the responses as to their relevance to the work you expect them to undertake.

- What qualifications does the engineer have?
- What training and relevant experience has the engineer had (including safety training)?
- Is the engineer familiar with this publication?
- What equipment is the engineer using to measure stopping performance?
- When was that equipment last calibrated?
- Can the engineer provide a copy of the calibration certificate?
- How does the engineer check that the maximum gauging force is not being exceeded?
- Can the engineer provide a specimen service report?

96 Engineers should have received product specific training and training on the health and safety aspects of guillotines. They should be familiar with and understand the content of this book and carry stopping performance test equipment which should be recalibrated every twelve months as a minimum.

When not to wait six months

97 Inspections and tests should be carried out every six months even if the guillotine continues to function and operate correctly. However, where the guillotine shows any signs of abnormal behaviour during the intervening six months, additional inspection and tests should be carried out. Examples of abnormal behaviour include lockouts, overruns and the malfunctioning of any safety component. Continual use of a machine on a three-shift cycle may require inspection more frequently than every six months.

Ancillary handling equipment

98 When connecting automatic or semi-automatic paper handling equipment to a guillotine control system, ensure that the integrity of the safety systems on both machines is maintained, particularly if interconnecting systems have been supplied by different manufacturers. As a user, you should ensure that retrospectively fitted additional handling equipment is of the same safety standard and integrity as the guillotine. The need for handling equipment will often be identified by assessments made under the Manual Handling Regulations 1992.²

99 When choosing such equipment, make sure you design the job to reduce the risk of upper-limb disorders (ULDs) by applying ergonomic principles to the machinery, work stations and work methods so that the job fits the person. Advice on these matters including training requirements is contained in a number of HSE publications.^{2,8,10-12}

Modifications and servicing

100 As a user, the key points to remember are:

- never make modifications, additions or conversions which might affect safety without reference to a competent guillotine engineer. This also applies to the installation and adjustment of safety devices, valves and guarding, as well as to welding work carried out to the load bearing elements of the equipment;
- never attempt to modify the software of programmable control systems;
- ensure that modifications to the controls and safety systems at the machine are recorded in the log and revised circuit diagrams are supplied by the manufacturer/supplier;
- review and where necessary revise existing risk assessments following modification;
- do not exceed the manufacturer's maximum load carrying capacity;
- remember that some equipment such as scissor lifts and pile hoists will be subject to the thorough examination requirements of the Lifting Operations and Lifting Equipment Regulations 1998³ and the Pressure Systems and Transportable Gas Containers Regulations 1989.¹³ Always have lifting/lowering equipment's pneumatic, mechanical, hydraulic and electrical systems regularly examined, especially such items as chains, air receivers, hydraulic cylinders and hoses.

Safe working practice

101 Observe the following good practice:

- Before initiating machine motion, make sure that nobody is at risk.
- Never switch off or remove pressure, suction or ventilation devices when the machine is operation.
- Ensure that guillotines with ancillary handling equipment are only operated by competent staff who are familiar with both.
- Define the operator's responsibilities and give the operator the authority to refuse instructions by others that are unsafe.
- Make sure any person undergoing training or instruction is being supervised by an experienced operator.
- In the event of any changes in behaviour of the machine during operation, stop the machine immediately, lock off and seek advice from a competent engineer.

Section 3 Engineer's responsibilities and competence

Legal requirements

102 As a guillotine engineer/engineer surveyor, you need to make sure that you comply with a number of legal requirements. These are summarised in the box insert. The information within this section and Section 4 will provide you with practical and technical guidance to help you to comply. If you inspect/service a guillotine which fails performance tests or does not comply with the technical standards within this book, you should advise the user accordingly in writing.

Do not issue an inspection/test certificate without recording the defects.

Relevant legislation

The Health and Safety at Work etc Act 1974¹⁴ places a duty on those conducting an undertaking, such as the provision of a guillotine inspection and maintenance service, to do so in a way which does not endanger the health or safety of those who are not in their employment, including the guillotine operator.

The Provision and Use of Work Equipment Regulations 1998⁶ (PUWER 98) apply to those who control to any extent the use of work equipment such as a guillotine. Engineers taking responsibility for inspection and servicing work are to an extent exercising control over the use of guillotines and will have duties under the following aspects of the Regulations:

- equipment is maintained and inspected in accordance with the guidance in this book;
- dangerous parts of machinery are guarded;
- controls and control systems are unambiguous, reliable and perform all the tasks necessary for safe operation, including minimised failure to danger, eg provision of emergency stop and other controls;
- records of inspection are provided.

Competence

103 Guillotine engineers should be competent. They will normally be a qualified mechanical or electrical/electronic engineer, with at least a City and Guilds, ONC or HND qualification, or equivalent training/experience. Engineers should normally have suitable and sufficient experience of guillotines with at least one years' experience of the make of machine to be supplied or serviced, together with product specific training and training on the health and safety aspects of guillotines. Engineers should be familiar with and understand the content of this book. Engineers should be fully aware of the limitations of their own knowledge and expertise and, where necessary, have the ability to call upon the services of specialists to ensure safety at the guillotine.

Accreditation of inspecting engineers

104 At the date of publication, there is no specific scheme for accreditation of guillotine engineers who carry out inspection although the United Kingdom

Accreditation Service (UKAS) has published guidance (RG1)¹⁵ which, together with European Standard EN 45004: 1995 provides guidance on appropriate qualifications for competent engineers inspecting power presses and their associated guards and protection devices. Similar qualifications can be considered for those inspecting guillotines and their safeguard arrangements. There is no requirement under health and safety legislation that inspecting engineers must be accredited, but accreditation can be taken as one indication of competence.

Assessment of competence

105 Engineers should be prepared to answer the following questions from guillotine users before being employed:

- What relevant qualifications do you have?
- What experience do you have on the machine in question?
- What training have you had?
- Are you familiar with the guidance in this publication?
- Can you provide the names of other users whose machines you have serviced?
- What equipment are you using to measure stopping performance?
- When was that equipment last calibrated?
- Can you provide a copy of the calibration certificate?
- How do you check that the recommended maximum gauging force is not being exceeded?
- Can you provide a specimen service report?

An operator's left hand was amputated on a 32 inch (813 mm) guillotine. The blade and clamp operated when all six light beams of the AOPD were broken simultaneously. This occurred as a replacement solenoid valve had been incorrectly wired by the supplier engineer.

Inspection and testing of guillotines

106 As a competent guillotine engineer, you have a pivotal role in ensuring the continued safe operation of the machinery you inspect. It is crucial that inspection and test work is performed rigorously so that any deterioration in the machine or safeguard performance is detected and rectified at the earliest opportunity.

107 Make sure you perform all of the following checks where relevant to the machine being inspected in addition to the recommended daily and monthly checks normally carried out by the user (see paragraphs 85-93):

All machines

108 On all machines which have the relevant equipment, carry out tests to ensure that:

- on machines manufactured after 1995, the dynamic gauging force does not exceed 500 N and the static gauging force does not exceed 300 N;
- on machines manufactured before 1995, in general the dynamic gauging force should not exceed 500 N and the static gauging force should not exceed 300 N, but exceptionally the static gauging force may reach a maximum of 500 N at 60% pile height;
- on machines with a mechanical clamp, the static gauging force is limited to a maximum of 300 N by a tensator spring. These are not available from the guillotine manufacturers, but are readily obtainable from other sources. The linkage should be smooth in operation and arranged so that clamp and pedal movement are proportionate;

- on machines with electrically operated clamps, movement of the clamp is only possible by two-hand-control operation with the front guard in position.

ESPEs

109 Check that:

- the relevant user-checks detailed in paragraph 87 of Section 2 can be satisfied;
- the position of the AOPD is the correct distance from the dangerous parts as specified on the information plate;
- the overall stopping performance does not exceed that stated on the information plate;
- the detection capability of the system accords with the manufacturer's instructions;
- the stopping performance monitor and overrun detection system where fitted are correctly positioned and fitted and are working to the manufacturer's recommendations;
- clamp gauging forces do not exceed the maximum figures given in paragraph 108;
- the brake and clutch where fitted are working to the manufacturer's recommendations and are uncontaminated by oil or grease to the extent that this would affect stopping performance. Internal examination should normally take place at approximately two-year intervals, subject to manufacturer's recommendations and/or wear;
- the machine primary control element(s) are functioning correctly and are uncontaminated by oil or grease;
- no lockouts have occurred by verifying with the operator;
- there are no other mechanical or structural aspects that would prevent the knife stopping or reversing when required;
- the guillotine controls and connections to the AOPD have not been adversely modified and that any modifications have been recorded in the log;
- the condition of the control gear, programmable electronic-based control system enclosures, cams, cam switches, and their fixings are free of wear damage or contamination by oil and dirt;
- cams are pinned.

110 A report pro forma to attach to the machines log is provided in Appendix 4.

Interlocking guards

111 Check that:

- clamp gauging forces do not exceed the maximum figures given in paragraph 108;
- the relevant user checks detailed in paragraphs 88-90 and 93 of Section 2 can be satisfied;
- the brake and clutch are performing to the manufacturer's recommendations and are uncontaminated by oil or grease to the extent that this would affect stopping performance.

112 A report pro forma to attach to the machines log is provided in Appendix 4.

Sweepaway guards

113 Check that:

- sweepaway guards have been upgraded to meet the standards detailed in paragraph 37 of Section 1;
- clamp gauging forces do not exceed the maximum figures given in paragraph 108;

- the relevant user checks detailed in paragraphs 91-92 of Section 2 can be satisfied;
- the guard operates both during a normal stroke and in a simulated overrun situation;
- guard movement is caused by part of the machine unaffected by the height of the knife carrier (unless the height of the carrier does not have to be altered to accommodate different knives);
- the force driving the guard is sufficient to remove the operator from the area;
- where the guard retracts under power or direct mechanical linkage, trapping between guard arms and the machine frame is prevented;
- the brake and clutch are performing to the manufacturer's recommendations and are uncontaminated by oil or grease to the extent that this would affect stopping performance.

114 A report pro forma to attach to the machines log is provided in Appendix 4.

Section 4 Technical standards for existing machinery and the supply of second-hand machinery

Introduction

115 As a supplier of used guillotines or a guillotine engineer, you need to make sure that all machines you supply or work on are safe. The practical effect of the legal requirements with which you need to comply, is that any machine of any age must meet the standards set out in this section. Remember that:

- Before you supply a used guillotine, you have a legal duty to carry out all the modifications and upgrading work necessary to meet the standards detailed in this section.
- If you provide an inspection and test service for guillotines in use, you have a duty to advise the user of any necessary modifications or upgrading work.

Relevant legislation

The Supply of Machinery (Safety) Regulations 1992 (SMR)¹⁶ apply to the first supply of machinery into the European Economic Area (EEA), and only where this has happened after 1 January 1993. If you supply second-hand machinery which was first used before 1993 inside the EEA, without substantially refurbishing it, the machinery does not need to comply with these Regulations. Similarly, if you are simply re-supplying used CE marked machinery, these Regulations do not apply. In either case you will still have duties under Section 6 of the Health and Safety at Work etc Act 1974 (HSW Act).

If the machine has been refurbished to the extent that almost all the replaceable parts are new, it would be considered to be new machinery to which SMR would apply. The addition of new guards or control devices would not make the machine 'new', but complete redesign of the hydraulic system and replacement of drive motors and control circuits would. Where SMR does apply, the guillotine will need to comply with the current European standards detailed in Section 5 of this book.

Notwithstanding duties covered under SMR, Section 6 of the HSW Act¹⁴ applies to the resale of all used workplace machinery, and requires that the guillotine is designed and constructed so that it is safe and without risk to health when it is used at work. It also requires that adequate information is supplied. These requirements will not be satisfied unless upgrading to the standards detailed within this section is completed.

116 To make sure you comply with these requirements, when you prepare machinery prior to resale always:

- look for obvious defects, such as missing or defective guards or other safety devices, or inadequately protected electrical wiring;
- check that known risks will be properly controlled or that there is information about how they can be controlled;
- make sure you have provided, from an informed source, instructions on safe installation, use, adjustment and maintenance - see paragraph 117, 'Guillotine instruction manual and log';
- ensure warning signs are visible and easy to understand.

Guillotine instruction manual and log

117 The information you need to supply under Section 6 of the HSW Act includes;

- a complete operating manual - see Appendix 1 for full details;
- a copy of the EC Declaration of Conformity if first supplied after 1 January 1995;
- details of servicing work (maintenance, inspection and testing) and modifications undertaken;
- ownership history.

118 The last two bullet points comprise the guillotine log, for which a sample format is given in Appendix 2. If no log was acquired with the guillotine, make sure you provide a new one and include all available information.

Technical standards

Electrical safety and controls

119 Where upgrading is carried out, electrical equipment and control gear should be in accordance with European Standard EN 60204: Part 1 1998. In addition, EN 61310: Parts 1 & 2 1995 will apply to the indication, marking and actuation of electrical control gear at the guillotine. Work may be necessary to ensure that existing earthing and isolation arrangements meet the requirements of the 16th edition of the IEE Regulations.¹⁷

Gauging pedal

120 Foot-operated controls should be provided for gauging only.

121 For safe gauging ensure that:

- the outer, upper edge of the gauging pedal at rest is between
- 50 mm and 125 mm above floor level;
- the outer edge of the pedal is at least 150 mm in from the edge
- of the machine table at the operating position;
- the width of the gauging pedal does not exceed 225 mm;
- if it is possible to inadvertently operate the gauging pedal, it is shrouded.

Two-hand control devices

122 On all machines, engineers should ensure that it is only possible to start a cut by operating a two-hand control unless provided with fully enclosing guards with dual-channel control cross-monitored interlocking or equivalent.

123 Two-hand electrical controls should comply with EN 574: 1997. In particular:

- type 111C for electrical/electric driven knives, and
- type 111B for hydraulic/pneumatic driven knives.

Programmable electronic systems

124 Programmable electronic systems are frequently used to control clamp, knife and backgauge operation, normally in machines provided with a photoelectric system. Guidance for programmable electronic-based technologies used in safety-related applications is given in IEC 61508: Part 1 1998 and HSE publications.¹⁸⁻¹⁹

125 Make sure that the programmable electronic system has been arranged so that:

- stop signals from the ESPE or any other emergency stop, interlocking guard or trip device are applied directly to the primary control elements. No other control signal should be able to restart the machine until the stop device has been reset;
- there is full compatibility between the guillotine control system and the safety system;
- the design takes account of the action of the ESPE and/or other systems on the guillotine primary and secondary control elements;
- information on the condition of the machine safety system, eg curtain interrupted, is fed into the programmable electronic-based control system to update it;
- correct operation of the machine safety system cannot be overridden by incorrect operation of the programmable electronic-based control system;
- the programmable electronic-based control system allows the knife and clamp to be raised and lowered manually.

126 Before upgrading guillotines that incorporate programmable electronic-based safety-related control systems, obtain and keep proper documentation relating to the hardware and software elements and ensure that all modifications are assessed, recorded and dated. It is essential that modifications to programmable electronic-based control systems and devices consider the extent to which any alterations may affect the functional safety performance (or safety integrity level) of these safety-related systems.

Front guards

127 This section describes the standards for safeguards that need to be provided at the front of any reconditioned guillotine to prevent operator contact with the descending knife and clamp.

ESPE

128 ESPE should cause the guillotine control mechanism to stop or retract the knife and clamp before the operator can reach them. At present, the only type of ESPE applied to paper-cutting guillotines is the ESPE using AOPDs, normally either a light curtain or an arrangement of light-beam devices (see Sections 3.206 and 3.205 of BS IEC 61496: Part 2 1997).

Performance standards for pre-1985 guillotines

129 Machines originally supplied before 1985 which do not meet the requirements of BS IEC 61496: Part 2 1997 (such as friction clutch machines with full-function monitoring) designed in accordance and complying with the standards detailed in the 1976 edition of the BPIF book *Guarding of guillotines and trimmers*

(see Appendix 5), require the following modifications to achieve a minimum acceptable standard:

- supply to the machine primary control element(s) to be interrupted when the guillotine locks out; and either,
- two machine secondary control elements arranged so that failure of one would be detected and power prevented from reaching the prime mover; or,
- a single machine secondary control element which if it fails to the permanently energised state will prevent the guillotine starting after the power supply has been switched on.

In addition:

- the guillotine is provided with two-hand control as described in paragraph 25 except that a delay of up to 1 second between operating each control is acceptable;
- if only one final switching device is provided, that if the final switching device fails, the failure is detected and the knife will stop immediately or at top-dead-centre, and the guillotine will lock out;
- where the guillotine is capable of fully automatic operation, there are in addition to the above requirements two final switching devices.

Performance standards for post-1985 guillotines

130 EN 61496: Part 1 1998 and BS IEC 61496: Part 2 1999 give the relevant standard for ESPEs supplied from approximately 1985. A type 4 ESPE should be used which should not respond to any source other than that transmitted by the system (see Figure 14).

131 Muting facilities can be automatically applied on the upstroke, manual selection being unnecessary. The means of actuating the mute should be keyed or pinned. For guillotines that have been provided with a retrofitted ESPE, it is necessary to ensure that the control system of the guillotine is designed to an equivalent standard, to assure the overall performance integrity. Any original control equipment not to an equivalent integrity of the safety system you are fitting should be replaced.

Type 4 ESPE

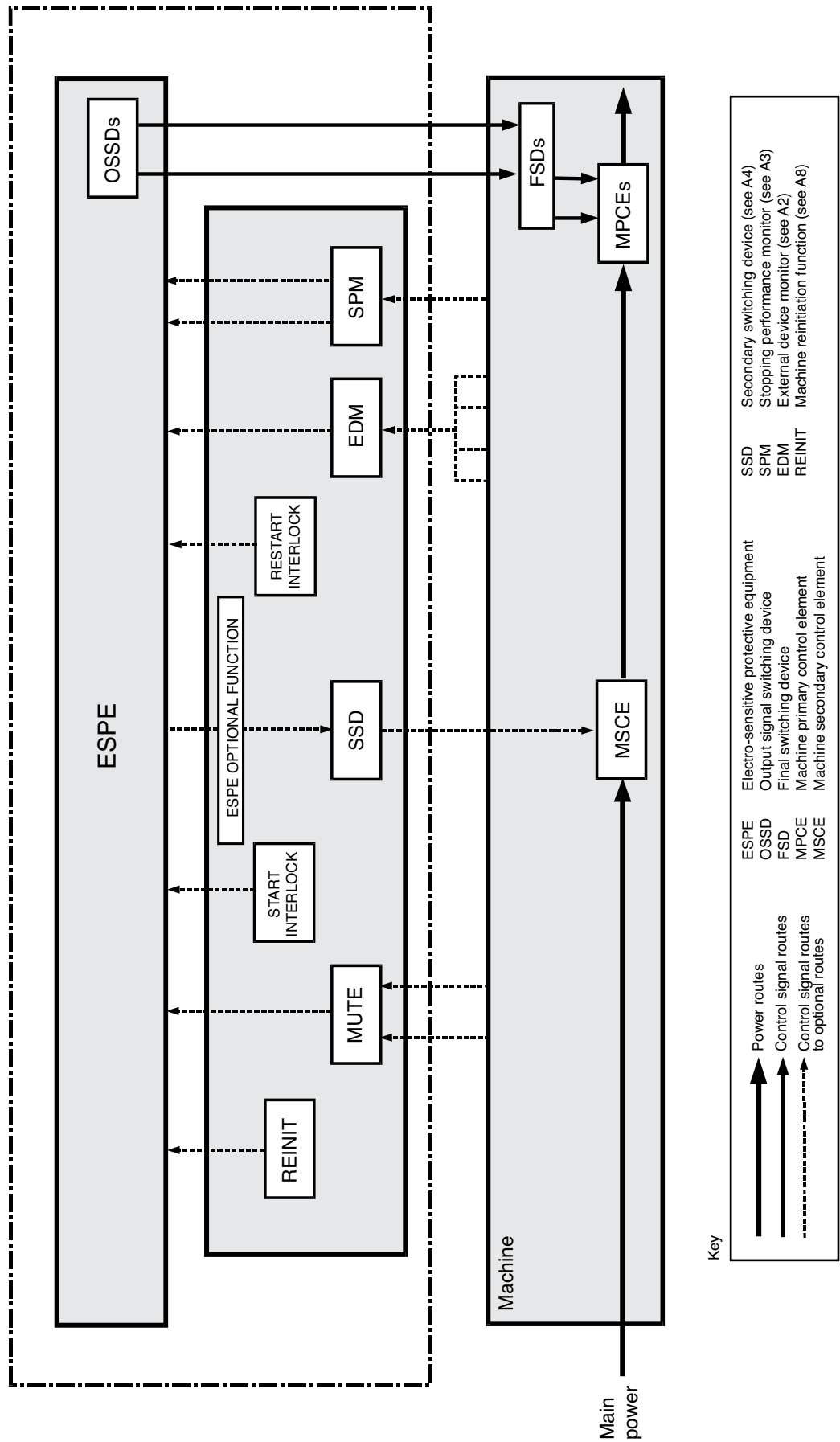

Figure 14 Schematic example for the interfacing of a type 4 ESPE to the guillotine

132 The overall safeguarding system should comply with the following:

- (a) it should not be possible for the clamp to descend under full power and cutting to commence while the ESPE is muted;
- (b) it should not be possible to 'strike on' while any part of a person interrupts the AOPD;
- (c) interruption of the AOPD during a dangerous part of the cutting cycle should cause the knife and clamp to stop or begin to retract without apparent delay. It must not be possible for the knife and clamp to be set in motion again until the two-hand control has been re-initiated.
- (d) during dangerous motion there should be no means of rendering the ESPE ineffective;
- (e) loss of any power source of the guillotine, internal or external, will not result in a failure that will compromise the safety integrity of any part of the machine;
- (f) the control system as a whole, including guillotine and safety systems, should be designed so that in the event of a single component failure, the overall safeguarding system will not fail to danger;
- (g) it should be so constructed that it is not adversely affected by the environmental conditions normally found in the printing and paper industries. Users and guillotine engineers should exchange information if conditions are outside the norm. (See also EN 60204: Part 1 1998 and IEC/EN 61496: 1997.) Aspects to bear in mind are:
 - (i) mechanical vibration and shock from the machine or from any other source;
 - (ii) dust, oil, moisture and corrosion;
 - (iii) variations of ambient temperatures;
 - (iv) variations of supply voltage and frequency;
 - (v) potentially explosive atmospheres (equipment used should be suitable for that environment);
 - (vi) electromagnetic disturbances;
- (h) the positioning and installation of the photoelectric curtain should ensure that the object detection capability is not adversely affected by any light reflective surfaces on the guillotine or the material likely to be cut;
- (i) most guillotines should have a visual indicator which the person carrying out the daily inspection and test of the curtain can see. This would indicate when insertion of the appropriately sized test piece has given rise to the correct AOPD. (This is a requirement in EN 61496: Part 1 1997);
- (j) that access to the danger zone from any direction not protected by an AOPD should be prevented by effective fixed or interlocking guards or screens, or other physical barriers such as side tables.

Machine primary control elements

133 An ESPE actuates the guillotine primary control elements to stop the knife and clamp before the operator can reach them. These elements are directly responsible for bringing the knife and clamp to rest and preventing any further dangerous movement while the photoelectric curtain (AOPD) is interrupted.

134 To ensure:

- (a) assured stopping capability;
- (b) prevention of unexpected startup (uncovenanted stroke);
- (c) that a level of safety performance commensurate with that of the ESPE is maintained; and
- (d) adequate facilities for safety monitoring means are available,

engineers should check that both the knife and clamp **each** have two machine primary control elements. However, if, in the guillotine design, power to both the knife and the clamp could be controlled by a single machine primary control element and the effect of its operation in both clamp and knife circuits can be monitored, then only two rather than four guillotine primary control elements need be provided. Machines supplied before October 1990 do not need to have two machine primary control elements for each of the knife and clamp, but the same integrity as detailed in paragraphs 130-132 should be achieved. In exceptional circumstances, a single machine primary control element can be provided where:

- (a) there is an electromagnetic clutch (the coil is the machine primary control element); **and,**
- (b) there is an electric motor fitted with a fail-safe brake (the winding of the motor is the machine primary control element). Standards of design for the electromagnetic clutch should be as per paragraphs 146-147.

The operator of a guillotine that did not have full-function monitoring, had three fingers of one hand amputated. The operator had reached in to remove a stack of paper thinking that the knife would stop at the top of its stroke. An undetected failure of a cam switch caused the guillotine to overrun, and then continue to cycle unguarded.

Stopping performance monitoring

135 Engineers should check that:

- clutch-operated mechanical guillotines are equipped with stopping performance monitoring;
- the stopping performance monitor is as close as possible to top-dead-centre and set so that the ESPE will lock out if the overall system stopping performance exceeds that used for the calculation of minimum curtain separation distance;
- stopping performance monitoring is carried out at least once per cycle (provided this is representative of the braking conditions which would occur if the AOPD was interrupted during dangerous motion of the knife or clamp).

136 Stopping performance monitoring systems include:

- (a) **fully comprehensive system**, as described in A3 of EN 61496: Part 1 1997;
- (b) **single cycle system**, eg overrun detection.

137 Full-function monitoring should include overrun detection for direct hydromechanical, clutch-operated and electromechanical guillotines, either by hard wired or programmable electronic-based control systems.

138 Check that the sensors are securely fixed in position, and their proper position should be permanently marked and contained within a secure enclosure.

Overrun direction

139 Certain types of knife mechanism (ie direct hydromechanical, clutch-operated mechanical and direct electromechanical) which are reciprocating in action, are fitted with machine position sensors (eg cam-operated switches). Ensure that lockout occurs if the crankshaft overruns top-dead-centre by more than 10°. The means of overrun detection should be in a secure enclosure. Where safety bolts/pawls are fitted to act as a mechanical scotch, ensure that they are fully functional.

Positioning of the AOPD relative to the cutting stick

140 When fitting a new ESPE ensure that the AOPD is positioned according to Sections 5.2.2 and 5.2.3 of EN 1010: Part 3 1999; EN 999: 1999 and HSG180.¹ Guidance for existing guillotines first supplied before the date of this publication is provided in paragraph 33 and Appendix 7.

Interlocking guards

141 Ensure that interlocking guards are fitted according to Section 5.2.3 of EN 1010: Part 3 1999.

142 All machines with interlocking guards should have a dual-channel control system which is cross monitored, ie dual-channel control interlocking with two guard position switches operating in opposite modes (one per channel) which should be cross monitored. Operation of the clamp and knife is normally by means of a two-hand control device but in this case may be by means of a single control device.

Automatic sweepaway guards

143 Machines fitted with automatic sweepaway guards should not be resold after the date of publication of this book.

144 Never replace a sweepaway guard with an ESPE where the machine is fitted with a brake which may fail and cause danger.

145 If you provide an inspection and test service for existing guillotines with sweepaway guards, refer to Section 1 paragraph 37 for the relevant standards.

Brake and clutch design

146 Ensure that any brake or clutch used complies with the following:

- (a) electric power supply failure, or loss of pneumatic or hydraulic pressure, should immediately activate the brake, and where appropriate, disengage the clutch;
- (b) they should be capable of performing satisfactorily during maximum sustained use;
- (c) overheating should be prevented by dissipation;
- (d) failure of any one component should not cause rapid consequential failure of other components;
- (e) the potential for corrosion of the working parts which might affect the efficiency of the clutch and brake should be minimised;
- (f) the design and positioning of brakes should ensure that lubricants do not reach the friction surfaces;
- (g) any necessary working clearances for clutches should be sufficient to ensure that friction drag leading to unintended movement of the knife or clamp cannot develop even under the most severe operating conditions;
- (h) any friction linings to be replaced should be to the manufacturers specification and fastened so that they are unlikely to become detached during use;
- (i) accumulation of dust or debris produced from frictional surfaces should be minimised in areas where it might cause drag or seizure; in addition, the design should ensure that fragments from broken clutch or brake components are unlikely to cause failure;

- (j) where the clutch and brake are combined, the connection between clutch and brake should be robust and as short and direct as possible to ensure correct synchronisation of the clutch and brake;
- (k) where diaphragm clutches are used, they should be designed and installed to minimise the possibility of failure, due, for example, to over stressing or fatigue; sharp edges should be avoided.

147 Ensure that any springs used for applying the brake or disengaging the clutch are adequately rated for safety and strong enough to ensure prompt and effective brake application. Compression springs should be used for disengaging the clutch and they should not be over stressed. A single spring should not be relied on for these duties unless equivalent safety is assured by other means. Any set of springs should be uniform in dimension, quality and rating, and the failure of one spring should not prevent the brake from operating effectively nor affect the ability of the clutch to disengage upon release of the engaging force. The springs should be so loaded that, when correctly adjusted, the springs' anchorage can be locked to prevent risk of slackening back. The arrangements for spring housing and guiding and of guide pins, should minimise any risk of binding.

Hydraulic design

148 The clamp is commonly driven hydraulically and many guillotines also have hydraulic knife operation. Check that all hydraulic components are of adequate strength and suitable for the purpose for which they are to be used.

149 Neither loss of electrical power to any solenoid nor loss of hydraulic pressure should cause danger. The hydraulic system should be designed so that the knife and/or clamp can be stopped or reversed at any point on the descending stroke.

150 Hydraulic systems should be designed and constructed to withstand the maximum system design pressure, and be arranged to avoid generation of harmful transient pressures. System protection should be provided where injury or damage may result from either excessive or inadequate hydraulic pressure.

151 Relief valves should be provided to prevent over-pressurisation and should be such that they can be adjusted only by qualified maintenance staff.

152 The provision of gauges or gauge connection points for diagnostic tests of both primary and secondary (pilot) pressure is recommended.

Control valves

153 Where upgrading of control valves is undertaken, ensure that where there is a single-control valve, means are provided to detect any failure of this device within one stroke of the machine and that this results in lockout.

154 Monitored solenoid-operated valves should be designed to ensure that the monitor device always registers each of the actual piston/spool positions. Solenoid-operated valves can have means of manual operation and should not bypass the safety device(s). However, manually operated devices should be designed to prevent, as far as practicable, inadvertent or careless operation.

Gravity fall

155 Protection against gravity fall of the knife and clamp should be provided by:

- (a) external return springs (with two-yearly replacement); or
- (b) a spring return single acting cylinder; or
- (c) a pilot-operated check valve in association with a counterbalance valve.

156 Check-valves which protect against gravity fall should be mounted directly onto the hold-up cylinder(s). Only seated valves should be used as check-valves to support the knife and clamp because they are less likely to be affected by dirt in the hydraulic system than spool valves.

157 Oil from the return area of a cylinder should be passed through the main control valves or, if this is not possible, through auxiliary valves, the operation of which depends totally on the supply of pilot oil from the main control valves. This is necessary even when the guillotine is fitted with seated 'hold-up' valves since it provides back-up security.

158 Advice is contained in BS EN 982: 1996.

Section 5 Additional information for suppliers of new machines

Legal requirements

Relevant legislation includes:

- the Supply of Machinery (Safety) Regulations 1992;¹⁶
- Section 6 of the Health and Safety at Work (etc) Act 1974;¹⁴
- the Electrical Equipment (Safety) Regulations 1994.²⁰

The **Supply of Machinery (Safety) Regulations 1992** apply to the supply of all new machinery manufactured or supplied in the UK, wherever it is to be used in the EEA.

The term 'supply' applies to all those engaged in the supply process and includes agents who solely make the arrangements for a sale on behalf of the manufacturer and user.

They require all UK suppliers and manufacturers to make sure that:

- the machinery supplied meets the relevant essential health and safety requirements which are listed in the Schedule to the Regulations, including the provision of sufficient instructions;
- a technical file has been assembled;
- there is a 'declaration of conformity' for the machine which should be issued with it;
- there is a 'CE' marking attached to the machine.

Detailed guidance on these Regulations is given in the publication *DTI product standards - machinery: Guidance notes on UK Regulations*.²¹

Suppliers' responsibilities

159 The Machinery Directive has been implemented in all EEA countries but as an importer of machinery into the UK you still need to make sure that the machinery is safe before supplying it. Use the following checklist if importing from the EEA:

- look for obvious defects, such as missing guards or other safety devices, or inadequately protected wiring;
- check that known risks from the machinery when it is in use will be properly controlled or that there is information on how they can be controlled;
- make sure the manufacturer has provided instructions for safe installation, use, assembly, commissioning, safe handling, adjustment and maintenance. A detailed list of the contents of operating and servicing manuals is given in Appendix 1;
- make sure the instruction manual is written in English if the machinery is for use in the UK. The maintenance instructions may however be written in another language if specialised staff from the manufacturer or supplier will carry out maintenance;

- provide a suitable log for the user to record ownership history, details of servicing and modifications, and test certificates.
A sample format is provided in Appendix 2.
- ensure power requirements, weights and floor loading and heat output, where appropriate, have been checked;
- ensure that any warning signs are visible and easy to understand;
- check that it has a CE marking;
- check with the manufacturer if you have any concerns about any of the above matters;
- never assume that machinery is safe just because it has CE marking;
- check that the machine complies to BS EN 1010: Part 3 1999 and is not a machine that was destined for a non-EEA country

160 If you import from outside the EEA, you will take on the legal duties of the manufacturer.

Manufacturers' responsibilities

161 Manufacturers need to design and construct machinery so that it can be used safely. This includes action to:

- identify health and safety hazards, such as trapping, crushing and electrical shock, which are likely to be present when the guillotine and any associated handling equipment are in use;
- assess the likely risks;
- eliminate the identified risks or provide safeguards and information about any residual risk.

Conformity assessment

162 Before issuing a declaration of conformity, manufacturers should draw up a technical file. This should comprise:

- an overall drawing of the machine with drawings and diagrams of the control circuits;
- drawings, calculations and test results demonstrating conformity with the essential health and safety requirements;
- a list of relevant essential health and safety requirements, standards and other technical specifications;
- a description of the methods used to eliminate hazards;
- where appropriate, technical reports or certificates from competent bodies or laboratories;
- where relevant, any technical report containing test results of compliance with harmonised standards;
- a copy of the instructions for the machine.

New machines - harmonised standards

163 Manufacturers need to ensure that their products satisfy the essential health and safety requirements. There are an increasing number of harmonised European Standards that will help you to do this. The detailed harmonised standards for guillotines are specified in EN 1010: Part 3 1999.

164 Other relevant standards include:

- EN 292: 1991
- EN 294: 1992
- BS EN 574: 1997
- BS EN 954: Part 1 1997
- BS EN 982: 1996
- BS EN 983: 1996
- EN 999: 1999
- EN 1037: 1996
- EN 1050: 1997
- EN 1088: 1996
- EN 60204: Part 1 1998
- BS EN 60947: Parts 4 (1) 1992
- BS EN 61496: Part 1 1997
- BS EN 61496: Part 2 1997
- IEC 61508: Part 1 1998 (NOTE: This a seven-part standard which deals with all aspects of the functional safety of safety-related systems. Parts 1, 3, 4 and 5 are available as IEC standards while Parts 2, 6 and 7 are currently final draft international standards (FDIS). It is anticipated that these Parts will be available as IEC standards by the end of 1999.)

HSE publications

- HSG180¹
- HSG43²²

For further details, see the *Reference* section.

Appendix 1 Contents of instruction manuals

For all machines:

- 1 Name and address of manufacturer/supplier.
- 2 Machine model and type.
- 3 The method and actuation of the knife and clamp.
- 4 The modes of operation.
- 5 Any potential system hazard and recommended safe systems of work, eg knife changing and cleaning.
- 6 A description, including circuit diagrams, of the control and safety system.
- 7 A general description, including hydraulic/mechanical/pneumatic diagrams, of knife and clamp operation.
- 8 Supply voltage and frequency.
- 9 Dynamic and static gauging forces.
- 10 A description of correct guard operation.
- 11 Details of six-monthly examinations and adjustments including overall stopping performance of the knife in milliseconds.
- 12 Action required if the knife sticks in a pile or the shear bolts/pins fail.
- 13 Instructions for periodic lubrication, adjustment and maintenance.

Additional information for guillotines with a hydraulically operated knife/clamp:

- 1 Maximum and minimum working pressures for both clamping and gauging operations and how to check them.
- 2 Settings for adjustable pressure relief or reducing valves and how to check them.
- 3 A description of actuator and valve function.
- 4 Accumulator capacity and initial pressure setting.
- 5 Types of filter required and degree of filtration in microns.
- 6 The type of hydraulic fluid that should be used.
- 7 For clutch-operated mechanical guillotines, the correct method of maintaining the brake and clutch settings should be detailed.
- 8 For machines with electrosensitive safety systems, a plate should be affixed to the machine in accordance with EN 999: 1998 which gives the following information:
 - overall system response time (in milliseconds);
 - object detection sensitivity in millimetres;
 - minimum AOPD separation distance in millimetres.

Appendix 2 Sample logs

Machine Log

Part 1 of 4 - Ownership history

Machine model/type: Serial no:

Note: Upon installation/commissioning, inspection checks should be carried out.

Name and address of manufacturer/agent
first supplying:

.....
.....
.....
.....

Name and address of first user:

.....
.....
.....
.....

Date sold:

Date of safety check:

Name and address of new agent:

.....
.....
.....
.....

Name and address of new user:

.....
.....
.....
.....

Date sold:

Date of safety check:.....

Name and address of new agent:

.....
.....
.....
.....

Name and address of new user:

.....
.....
.....
.....

Date sold:

Date of safety check:.....

Name and address of new agent:

.....
.....
.....
.....

Name and address of new user:

.....
.....
.....
.....

Date sold:

Date of safety check:.....

Guillotine log

Part 2 of 4 - Commissioning, servicing and modifications

Results of commissioning inspections and tests:

To be recorded on each occasion the machine is moved to a new location (including within the same premises).

New location:
Engineer's name: Signature: Date:
Engineer's company:

Details of servicing: **To be next serviced on:**

Record of all details of servicing work carried out including repairs.

Engineer's name: Signature: Date:
Engineer's company:

Details of servicing: **To be next serviced on:**

Record of all details of servicing work carried out including repairs.

Engineer's name: Signature: Date:
Engineer's company:

Guillotine log

Part 2 of 4 - Commissioning, servicing and modifications (continued)

Technical details of any modifications made:

Record all details of any modifications made to upgrade the machine to current standards.

Engineer's name: Date:

Engineer's company:

Technical details of any modifications made:

Record all details of any modifications made to upgrade the machine to current standards.

Engineer's name: Date:

Engineer's company:

Details of failure to pass any in-house daily shift or monthly check:

Record all details and circumstances of any failure to pass routine checks or abnormal behaviour.

Operator:.....

Date:

Supervisor:.....

Details of failure to pass any in-house daily shift or monthly check:

Record all details and circumstances of any failure to pass routine checks or abnormal behaviour.

Operator:.....

Date:

Supervisor:.....

Guillotine log

Part 3 of 4 - Test certificates

Attach copies of **either** all photoelectric guard six-monthly test certificates with details of stopping performance and gauging force **or** interlocking/sweepaway guard monthly/six-monthly test certificates.

Guillotine log

Part 4 of 4 - Records of daily shift and knife-change checks

Attach copies of check sheets.

Appendix 3 Guillotine safety checklists

Daily or shift/knife-change checks (see paragraphs 85-90)

Machine make/model: Serial no: Week commencing:

| Test/check: state pass or fail | Mon | Tue | Wed | Thu | Fri | Sat | Sun |
|---|-----|-----|-----|-----|-----|-----|-----|
| All machines with two-hand control (including sweepaway guards) | | | | | | | |
| Guillotine should strike on when both controls are depressed within 0.5 second. | | | | | | | |
| <ul style="list-style-type: none"> ■ each control is operated independently and reset in turn. ■ one control is operated followed by other after 2-3 seconds delay ■ both controls are operated within 0.5 second but one is released mid-way through the stroke and then re-operated | | | | | | | |
| Machines with ESPDs | | | | | | | |
| Is the guard indicator working (where fitted)? | | | | | | | |
| Is recommended test piece detected (three positions)? | | | | | | | |
| Does knife and clamp stop when curtain is interrupted during stroke? | | | | | | | |
| Is fixed rear table guarding fitted and secured or does interlocked access gate prevent powered knife and clamp movement? | | | | | | | |
| Machines with interlocking guards | | | | | | | |
| Check guard cannot open during stroke if locking arrangement fitted | | | | | | | |
| Check that stopping efficiency is adequate by opening the guard at mid-stroke of first the knife and then the clamp (no locking arrangement) | | | | | | | |
| For machines with a single cut button where the guard has to be held down against spring pressure, check: <ul style="list-style-type: none"> ■ machine does not strike on if button is operated before guard closed ■ the guillotine strikes on when the control is released and re-operated with the guard closed ■ the knife stops if the guard is held closed but the control is released before the knife reaches bottom dead-centre | | | | | | | |
| Is access to rear of knife and clamp guarded? | | | | | | | |
| Checked by (operator's name): | | | | | | | |
| Confirmed by (supervisor's name): | | | | | | | |

**Monthly checks of machines with sweepaway or interlocking guards
(see paragraphs 91-93)**

Machine make/model: Serial no: Week commencing:

| Test/check: state pass or fail | Jan / Jul | Feb / Aug | Mar / Sep | Apr / Oct | May / Nov | Jun / Dec |
|--|-----------|-----------|-----------|-----------|-----------|-----------|
| Machines fitted with sweepaway guards | | | | | | |
| Does the main guard bar extend at least 500 mm by the time the knife or clamp has descended 50 mm? | | | | | | |
| Is the guard bar a maximum of 180 mm from the table at the lowest point of sweep? | | | | | | |
| Are linkages free from wear and securely attached? | | | | | | |
| Are the guard bars/screens firmly fixed to prevent access through the guard? | | | | | | |
| Is side access to the knife prevented by side guards or table extensions? | | | | | | |
| Machines fitted with interlocked guards | | | | | | |
| Are valves and electrical switches securely attached? | | | | | | |
| Are actuators such as cams, levers and linkages correctly aligned and attached? | | | | | | |
| Is the guard free from lateral movement which would cause the interlock switches to become mis-aligned and fail to engage? | | | | | | |
| Are the interlock switches and actuators free from wear that would allow knife operation when the guard is partly open? | | | | | | |
| | | | | | | |
| Checked by (operator's name): | | | | | | |
| Confirmed by (supervisor's name): | | | | | | |

Six-monthly inspection and test of machines with ESPDs (see paragraph 109)

Machine make: Model: Serial no:

| Inspection/test (to be performed in addition to daily shift checks) | Comments/result | Details of remedial work undertaken/advised |
|---|-----------------|---|
| Machines with ESPDs | | |
| Check that the position of the AOPD is the correct distance from the dangerous parts. Record minimum separation distance | | |
| Test object detection capability of AOPD against manufacturer's recommendation (state test piece size) | | |
| Examine stopping performance monitor (and indicator) and overrun detection system against manufacturer's recommendations to ensure correct positioning and installation | | |
| Examine any brake and clutch to manufacturer's recommendations. State air gap | | |
| Test overall stopping performance against manufacturer's recommendation and record result in milliseconds | | |
| Check that dynamic and static gauging forces do not exceed 500 N and 300 N respectively | | |
| Examine and test the machine primary control elements to ensure correct operation | | |
| Inspect the guillotine to ensure there are no mechanical or structural aspects that would prevent the knife and clamp from stopping or reversing when called upon | | |
| Examine and inspect the controls and connections to the photoelectric safety system to ensure no modifications have been made which adversely affect the system | | |
| Check the condition of control gear, programmable electronic system enclosures, fixings, cam switches and cam wear and that they are free from dirt and oil contamination | | |
| Have daily or shift/knife change checks been completed? State pass or fail and provide details | | |
| | | |
| Signature of engineer: | Date: | |

Six-monthly inspection and test of interlocking and sweepaway guards (see paragraphs 111 and 113)

Machine make: Model: Serial no:

| Inspection/test (to be performed in addition to daily shift checks) | Comments/result | Details of remedial work undertaken/recommended |
|--|-----------------|---|
| Machines fitted with interlocking guards | | |
| Are valves and electrical switches securely attached? | | |
| Are actuators such as cams, levers and linkages correctly aligned and attached? | | |
| Is the guard free from lateral movement which would cause the interlock switches to become mis-aligned and fail to engage? | | |
| Are the interlock switches and actuators free from wear that would allow knife operation when the guard is partly open? | | |
| Examine the brake and clutch to ensure that they are performing to the manufacturer's recommendations. Adjust as necessary and state air gap | | |
| State whether dynamic and static gauging forces exceed 500 N and 300 N respectively | | |
| Have daily or shift/knife-change checks been completed? State pass or fail and provide details | | |
| Machines fitted with sweepaway guards | | |
| Does the main guard bar extend at least 500 mm by the time the knife or clamp has descended 50 mm? | | |
| Is the guard bar a maximum of 180 mm from the table at the lowest point of sweep? | | |
| Are linkages free from wear and securely attached? | | |
| Are the guard bars/screens firmly fixed to prevent access through the guard? | | |
| Is side access to the knife prevented by side guards or table extensions? | | |
| Examine the brake and clutch to ensure that they are performing to the manufacturer's recommendations | | |
| State whether dynamic and static gauging forces exceed 500 N and 300 N respectively | | |
| Have daily or shift/knife-change checks been completed? State pass or fail and provide details | | |
| | | |
| Signature of engineer: | Date: | |
| Signature of company manager: | Date: | |

Appendix 4 Glossary

Active opto-electronic protection devices (AOPD) - a light curtain and/or light beam device comprising emitting and receiving elements which form a detection zone.

Assured stopping capability - the use of two independent control mechanisms each of which is capable of stopping the dangerous part.

Backgauge - a moveable stop, behind and parallel to the cutting stick.

Curtain separation distance - the distance between the area of detection of the AOPD and the cutting stick.

Cutting stick - a flexible strip of material inserted into the machine table in line with the knife.

Detection zone - the zone within which a specified test piece will be detected by the electrosensitive protective equipment (ESPE).

Dual-channel control interlocking - interlocking with two separate power interrupting devices, arranged in series so that the operation of either will result in the interruption of the power medium.

Electrosensitive protection equipment/device (ESPE/D) - An assembly of devices and/or components working together for protective tripping or presence sensing and comprising as a minimum:

- a sensing device;
- control/monitoring devices;
- output signal switching devices.

Final switching device - the component of the machines safety-related control system that interrupts the circuit to the machine primary control element when the output signal switching device goes to the OFF-state.

Full-function monitoring - see Appendices 5 and 6 for detailed explanation.

Gauging - use of the gauging pedal to lower the clamp down on to the material to be cut to allow the material to be accurately positioned.

Interface - the sum of all the points of electrical interaction between the machine and safety system.

Knife holder/carrier - a device attached to the knife during changing which covers the cutting edge of the blade and provides a secure handle at the point at which the knife is bolted into the machine.

Light curtain - an active opto-electronic protective device (AOPD) comprising an integrated assembly of one or more emitting element(s) forming a detection zone with a detection capability, both specified by the supplier.

Lockout condition - a condition, initiated by a fault, preventing normal operation of the electrosensitive protective equipment (ESPE) which is automatically attained when all output signal switching devices and, where applicable, all final switching devices and secondary switching devices are signalled to go to the OFF-state.

Machine primary control element - the electrically powered element that directly controls the normal operation of a machine in such a way that it is the last element (in time) to function when machine operation is to be initiated or arrested. This element can be, for example, a mains contactor, a magnetic clutch, or an electrically operated hydraulic valve.

Machine secondary control element - a machine control element, independent of the machine primary control element, that is capable of removing the source of power from the prime mover of the relevant hazardous parts. The machine secondary control element is normally controlled by the secondary switching device. This element can be, for example, a mains contactor, a magnetic clutch or an electrically-operated hydraulic valve.

Muting - a temporary automatic suspension of a safety function or functions by safety related parts of the control system.

Object detection capability - the minimum size of test piece which when placed at right angles to the AOPD will be detected.

OEM - original equipment manufacturer.

Overall safeguarding system - the combination of the ESPE and machine primary control elements with the secondary control element and clutch or braking system which together cause the clamp and knife to halt or retract when the AOPD is interrupted.

Overall system response time - the time interval resulting from the sum of the electro-sensitive protective equipment (ESPE) response time and the time to cessation of hazardous machine operation.

Overall stopping performance - see overall system response time.

Overrun - the continued movement of the knife or clamp beyond top-dead-centre following a cutting cycle.

Programmable guillotine - a guillotine capable of completing a predetermined series of backgauge movements and/or capable of co-ordinating cutting cycles with backgauge movements.

Secondary switching device (SSD) - A device which, in a lockout condition, performs a back-up safety function by going to the OFF-state and initiating an appropriate machine control action, eg de-energising the machine secondary control element.

Side lays - fixed vertical guides at either side of the rear table extending from the throat of the machine.

Striking-on - initiation of full pressure descent of the clamp and knife by operation of the controls.

Test piece - an opaque cylindrical object of low reflectivity used to test the AOPD detection capability.

Throat - the area bounded by the cutting stick, side lays and underside of the clamp.

Appendix 5 Extract from British Printing Industries Federation booklet *Guarding of guillotines and trimmers*, December 1976 edition

The following extract details a standard which is applicable only to guillotines manufactured and in use before 1985 - see paragraph 129.

Photoelectric devices

- 1 The light curtain of these devices is designed to stop the motion of the knife or clamp before a person's hands can reach the danger zone. Each operator should receive instructions on the functioning of the device to enable recognition of any defects in its operation. The mechanical, electrical and electronic parts of the equipment should be periodically inspected and efficiently maintained by a competent person, and records should be kept.
- 2 The standard of performance of photoelectric devices should be as follows:
 - (a) if any part of a person is under the knife or clamp it must not be possible for the knife or clamp to be set in motion by the release of the brake and/or engagement of the clutch;
 - (b) in the event of an interruption of any of the light beams while the knife or clamp is descending, the knife or clamp must be brought to rest before the object which has caused the interruption can reach the space beneath the knife or clamp. It must not be possible for the knife or clamp to be set in motion again until the safety device has been completely restored to the clutch disengaged position;
 - (c) the device should be so installed and connected as to ensure that the knife and clamp cannot be brought into motion unless the device is in a fully operative condition;
 - (d) the safety device must not be rendered ineffective by stray light whether artificially, naturally or deliberately applied;
 - (e) access to the knife or clamp at the front of the machine from any direction not protected by the light curtain or screen should be effectively prevented by fixed guards, screen or extended side tables;
 - (f) arrangements should be made by the provision of effective guards or by additional electrosensitive devices, suitably positioned to prevent the machine being used if a person is standing between the light curtain and trapping area;
 - (g) the device must fail to safety in respect of failure of electrical or other power supplies and so far as it is reasonably practicable in all other respects it must not malfunction as a result of electrical interference and it must not be rendered ineffective by normal fluctuations in voltage and frequency;
 - (h) the device must be so constructed and mounted as not to be adversely affected by vibration or shock from the machine or from any other source;

- (i) the device and the associated electrical apparatus must be so enclosed as to prevent failure resulting from dust, oil, moisture or corrosion. Particular attention should be given to preventing dust and other foreign matter entering such enclosures when they are opened for maintenance or other purposes;
- (j) the equipment must not be rendered ineffective by variation in ambient temperature within the range 0 °C to 55 °C. The sensitivity as defined in (n) and (o) must be maintained throughout this temperature range and in an atmosphere of up to 95% relative humidity;
- (k) the device should be locked and the key accessible only to an authorised person (ie the factory occupier or such other person as may be appointed by him to be responsible for the proper operation of the apparatus);
- (l) the device should incorporate a system of full function monitoring in which an automatic check is provided to prove at each cycle of the machine that the guard and various parts of the guillotine are operating correctly. The check is made during the upstroke and if all parts of the safety system are operational, the knife will come to rest at top dead centre. If any fault causes the clamp or knife to overrun top dead centre, an overrun switch is brought into operation, which stops the machine in such a manner that operation can only be restored by an authorised person. On a full function monitored guillotine the following are checked:
 - (i) the operation of the light curtain itself. Where the sensing device comprises a number of discrete units (such as individual light beams) the automatic check must operate to prove that each unit is operating effectively;
 - (ii) the relays and contactors in the safety circuits, all being cross monitored so that any failure, for instance in the top dead centre overrun switch, results in lockout;
 - (iii) the machine electrics themselves such as the main contactors, which could conceivably weld or a component which could become faulty.
 - (iv) the clutch and brake. If the clutch drags or the brake wears so that the knife does not stop at the top, the top dead centre overrun switch is activated.

Requirements for full-function monitoring are given in the eighth report of the Joint Standing Committee on safety in the use of power presses entitled *Electrosensitive safety devices for friction-clutch press brakes*; [see Appendix 6]

- (m) where a guillotine may be operated in flammable or explosive atmospheres, additional precautions may be necessary to meet the requirements of Regulation 27 of the Electricity (Factories Act) Special Regulations 1944;
- (n) the sensitivity of the device should be such that it can detect the insertion of a standard test gauge of a diameter determined in accordance with the following table:

| | |
|--|--|
| Distance of plan of light curtain from the face of the clamp | 450 mm (18 inches) 610 mm (24 inches) |
| Diameter of test gauge | 40 mm (1.5 inches) 50 mm (2 inches) |

The sensitivity should not be capable of such adjustment as to render the apparatus ineffective as a safety device and the following test should be made at the commencement of each shift, once thereafter during each

shift and also before each production run after knife changing. A test gauge (see above table), preferably a long cardboard tube, should be thrust quickly through the light curtain in the direction of the knife and clamp while they are descending. If the speed of the response of the device and the sensitivity of the light curtain are adequate it should not be possible for the knife to damage the end of the tube.

Where it is necessary to allow for overhang of material, the maximum vertical distance between the outer light beam and the machine table should be as small as practicable and in no case greater than 175 mm (7 inches). In both cases the outer light beam should be a minimum horizontal distance of 635 mm (25 inches) from the face of the clamp.

- (o) in an alternative method of fitting the guard the outer light beam must not be less than 1050 mm (41 inches) from the face of the clamp measured horizontally at a minimum height of 765 mm (30 inches) above where the operator stands. In addition the distance between the inner light beam and the front edge of the table or between any pair of light beams must not be more than 150 mm (6 inches).

Appendix 6 Extract from the Health and Safety publication *Electro-sensitive safety devices for friction-clutch press brakes* eighth report of the joint standing committee on safety in the use of power presses

The following extract describes a full-function monitoring system applied to a press brake. The equipment used on a guillotine will differ, but the general principle of overrun protection is the same. Full-function monitoring is applicable only to guillotines manufactured and in use before 1985 - see paragraph 129.

Full-function monitoring

The illustration (Figure 1) is drawn diagrammatically to show the principles of full-function monitoring. The device is muted by means of switch 'A' just before bending begins, ie at minimum gap. The device remains 'off' until the press brake reaches a pre-set point in the return stroke, when switch 'B' simulates the condition of breaking the light beams simultaneously for a brief instant and a signal is given to stop the machine. This is arranged so as to bring the press to rest at top-dead-centre, (or bottom-dead-centre on an upstroking machine) and if it does not stop within a pre-set distance, it operates limit switch 'C' and all incoming electrical supply to the press is immediately isolated by a master circuit breaker or contractor. The press can only be restarted by using a re-set key.

A practical realisation of the system is necessarily more complex than the simplified diagram. Switch 'C' must be taken momentarily out of circuit at the beginning of each normal working stroke. It is also necessary for the photo-cells to be switched from a series to a parallel arrangement (by switch 'A' or by a separate switch) before the operation of switch 'B'. Failure to restore switch 'C' would result in loss of monitoring and failure to restore the cells to the series mode would result in loss of guarding. It is essential therefore, that provision be made in a practical system to ensure that both these types of failure would themselves be detected and would result in lockout of the incoming mains supply to the machine.

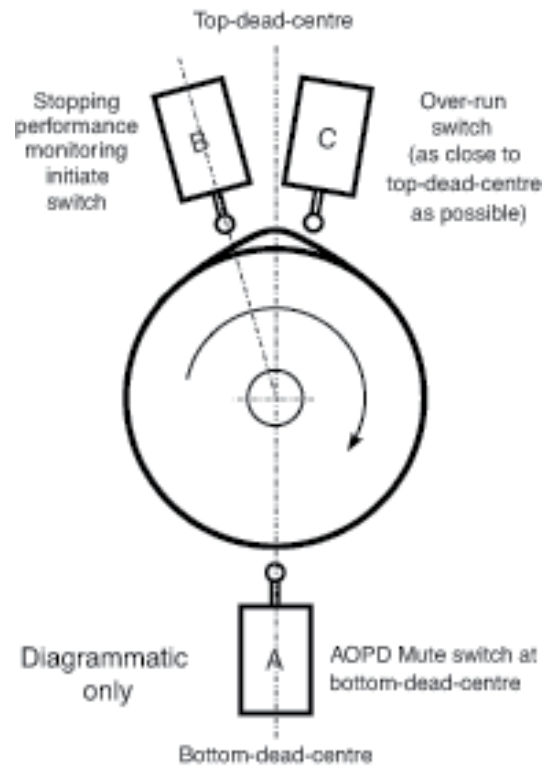

Figure 1 Diagram showing location of position switches for full function monitoring

Appendix 7 Method for determining the position of the AOPD relative to the cutting stick

The following extract details a standard which is applicable only to guillotines manufactured and in use before the date of this publication - see paragraphs 33 and 140.

1 The manufacturer should use reliable measurement techniques to ascertain the maximum overall system stopping performance (SP) in milliseconds, within which all guillotines built to the same specification should be able to perform. Tests to establish this should normally be carried out during the development of every model and be made at different points in the stroke and at different points along the knife and clamp.

2 To this figure of SP should be added:

- a) an amount in milliseconds which takes into account the tolerance (t) of the instrument and method used for taking the measurements; and
- b) a further amount in milliseconds which represents the maximum potential deterioration (e) in the stopping performance that is likely to have occurred after six months use. This should be determined empirically by tests designed to represent a period equivalent to six months use.

3 The overall system response time (RT) after is the sum of SP, t and e:
 $RT = SP + t + e$

4 The value of RT should be marked on a clearly visible and permanent information plate headed 'Standard to which guillotine is constructed'. It should be used for setting the stopping performance monitor, if fitted.

5 In addition, the guillotine manufacturer will need to know the object detection capability or sensitivity (S) of the photoelectric curtain namely the diameter of the smallest test piece (in millimetres) which will be detected at any position in the curtain when inserted at a right angle to the plane of the curtain. S may not be simply the spacing of the centres of adjacent beams. The value of S should be obtained from the curtain manufacturer (as described in BS 6491: Parts 1 & 2 1984 & 1987) and recorded on the information plate mentioned above.

6 The potential distance (P) that a hand can penetrate the curtain before it is detected should then be determined from the equation:
 $P = 3.4(S - 7) \text{ mm}$

7 The curtain should then be positioned so that no part of the photoelectric curtain is nearer the cutting stick than the minimum separation distance (D) where:
 $D = P + (RT \times 1.8) \text{ or } 255 \text{ mm, whichever is the greater}$

1.8 m/s is the derived hand speed for Category 1 machines. The value of D should also be recorded on the supplier's information plate.

8 As examples, the minimum separation distance (D) against (RT) is shown graphically at Figure 1 for values of S = 38 mm and S = 50 mm.

9 The values specified in paragraphs 5 to 7 are based on currently available knowledge and may be subject to amendment as a result of future development

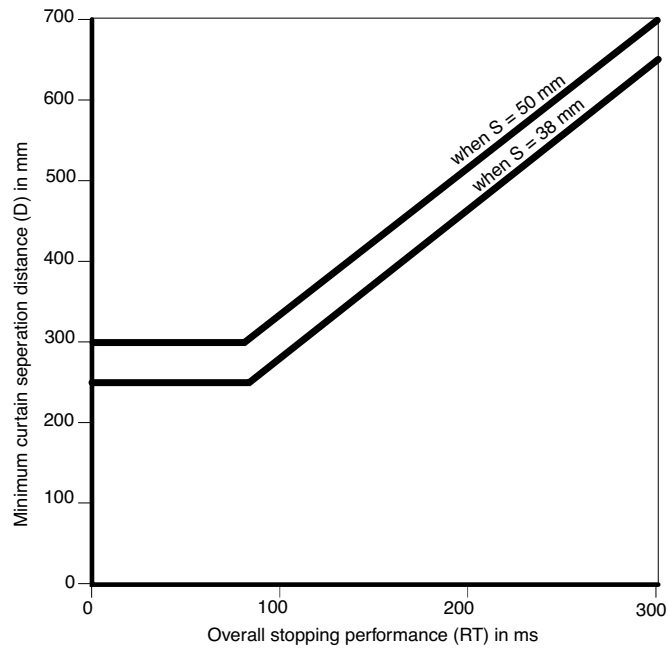

Figure 1 Graph of minimum separation distance against overall stopping performance

References

- 1 *The application of electro-sensitive protective equipment using light curtains and light beam devices to machinery.* HSG180 HSE Books 1999 ISBN 0 7176 1550 2
- 2 *Manual handling. Manual Handling Operations Regulations 1992. Guidance on Regulations.* L23 HSE Books 1998 ISBN 0 7176 2415 3
- 3 *Safe use of lifting equipment. Lifting Operations and Lifting Equipment Regulations 1998. Approved Code of Practice and Guidance on Regulations.* L113 HSE Books 1998 ISBN 0 7176 1628 2
- 4 *Buying new machinery.* INDG271 HSE Books (single copies free; ISBN 0 7176 1559 6 for priced packs)
- 5 *Management of health and safety at work. Management of Health and Safety at Work Regulations 1992. Approved Code of Practice.* L21 HSE Books 1998 ISBN 0 7176 0412 8
- 6 *Safe use of work equipment. Provision and Use of Work Equipment Regulations 1998. Approved Code of Practice and Guidance.* L22 HSE Books 1992 ISBN 0 7176 1626 6
- 7 *5 steps to risk assessment.* INDG163(rev) HSE Books 1998 (single copies free; ISBN 0 7176 1565 0 for priced packs)
- 8 *Printing industry: health and safety open learning training package.* HSE Books 1998 ISBN 0 7176 1481 6
- 9 *Young people at work: a guide for employers.* HSG165 HSE Books 1997 ISBN 0 7176 1285 6
- 10 *Work-related upper limb disorders: a guide to prevention.* HSG60 HSE Books 1990 ISBN 0 7176 0475 6
- 11 *Manual handling: solutions you can handle.* HSG115 HSE Books 1994 ISBN 0 7176 0693 7
- 12 *A pain in your workplace: ergonomic problems and solutions.* HSG121 HSE Books 1994 ISBN 0 7176 0668 6
- 13 *Pressure systems - safety and you.* INDG261 HSE Books 1997
- 14 *A guide to the Health and Safety at Work etc Act 1974 - Guidance on the Act.* L1 HSE Books 1992 ISBN 0 7176 0441 1
- 15 *Accreditation for in-service inspection of power presses and other specified machines and their safeguarding systems.* RG1 United Kingdom Accreditation Service Teddington 1999
- 16 *The Supply of Machinery (Safety) Regulations 1992.* SI 1992 No 3073 HMSO ISBN 0 11 025719 7
- 17 *The Institution of Electrical Engineers Regulations for Electrical Installations 16th Edition. (The IEE Wiring Regulations)* (obtainable from the IEE, PO Box 26, Hitchin, Herts, SG 5 1SA)

- 18 *Programmable electronic systems in safety-related applications: An introductory guide*. HSE Books 1987 ISBN 0 7176 1278 3
- 19 *Programmable electronic systems in safety-related applications: General technical guidelines*. HSE Books 1987 ISBN 0 7176 0545 0
- 20 *The Electrical Equipment (Safety) Regulations 1994* SI 1994 No 3260 HMSO ISBN 0 11 043917 1
- 21 *Product standards. Machinery Guidance notes on UK Regulations*. Department of Trade and Industry 1996. Copies available from DTI Business in Europe Hotline 0117 944 4888
- 22 *Industrial robot safety*. HSG43 HSE Books 1988 ISBN 0 7176 1237 6

British/European Standards

BS EN 292: 1991 *Safety of machinery - Basic concepts, general principles for design. Part 1 1991 Basic terminology, methodology. Part 2 1991 Technical principles and specifications*

EN 294: 1992 *Safety of machinery - Safety distances to prevent danger zones being reached by the upper limbs*

BS EN 574: 1997 *Safety of machinery. Two-hand control devices. Functional aspects. Principles for design*

BS EN 954: 1997 *Safety of machinery - safety related parts of control systems. Part 1 1997 General principles for design*

BS EN 982: 1996 *Safety of machinery - safety requirements for fluid power systems and their components - hydraulics*

BS EN 983: 1996 *Safety of machinery - safety requirements for fluid power systems and their components - pneumatics*

EN 999: 1999 *Safety of machinery - the positioning of protective equipment in respect of approach speeds of parts of the human body*

prEN 1010: 1999 *Safety of machinery - safety requirements for the design and construction of printing and paper converting machines. Part 3 Cutting machines*

EN 1037: 1996 *Safety of machinery - prevention of unexpected startup*

EN 1050: 1997 *Safety of machinery - principles for risk assessment*

EN 1088: 1996 *Safety of machinery - interlocking devices associated with guards. Principles for design and selection*

BS 5323: 1980 *Code of Practice for scissor lifts. Recommended design and safety requirements for fixed scissor lifts with a working height not exceeding 1.98 m ground or floor level and mobile vehicle and self propelled scissor lifts of any working height*

BS 6491: *Electrosensitive safety systems for industrial machines. Part 1 1984 Specification for general requirements. Part 2 1987 Specification for particular requirements for incorporating photoelectric sensing units*

EN 45004: 1995 *General criteria for the operation of various types of inspection bodies performing inspection*

EN 60204: 1998 *Safety of machinery - electrical equipment of machines. Part 1 Specification for general requirements*

BS EN 60947: 1992 *Specification for low voltage switch gear and control gear. Part 4-1 1992 Contactors and motor starters*

EN 61310: 1995 *Safety of machinery - indicative marking and actuation. Part 1- Requirements for visual, auditory and tactile signals. Part 2 - Requirements for marking*

IEC/EN 61496: *Safety of machinery - electro-sensitive protective equipment. Part 1 1997 General requirements and tests. Part 2 1997 Particular requirements for equipment using active opto-electronic protective devices (AOPDs)* IEC 61508: 1998 *Functional safety of electrical/ electronic/ programmable electronic (E/E/PE) safety related systems.* (NOTE: This a seven-part standard which deals with all aspects of the functional safety of safety-related systems. Parts 1, 3, 4 and 5 are available as IEC standards while Parts 2, 6 and 7 are currently final draft international standards (FDIS). It is anticipated that these Parts will be available as IEC standards by the end of 1999.)

IEC 61508: 1998 *Functional safety of electrical/ electronic/ programmable electronic (E/E/PE) safety related systems.* (NOTE: This a seven-part standard which deals with all aspects of the functional safety of safety-related systems. Parts 1, 3, 4 and 5 are available as IEC standards while Parts 2, 6 and 7 are currently final draft international standards (FDIS). It is anticipated that these Parts will be available as IEC standards by the end of 1999.)

Further information

For information about health and safety ring HSE's Infoline Tel: 0845 345 0055
Fax: 0845 408 9566 Textphone: 0845 408 9577 e-mail: hse.infoline@natbrit.com or
write to HSE Information Services, Caerphilly Business Park, Caerphilly CF83 3GG.

HSE priced and free publications can be viewed online or ordered from
www.hse.gov.uk or contact HSE Books, PO Box 1999, Sudbury, Suffolk
CO10 2WA Tel: 01787 881165 Fax: 01787 313995. HSE priced publications
are also available from bookshops.

British Standards can be obtained in PDF or hard copy formats from the BSI online
shop: www.bsigroup.com/Shop or by contacting BSI Customer Services for hard
copies only Tel: 020 8996 9001 e-mail: cservices@bsigroup.com.

The Stationery Office publications are available from The Stationery Office,
PO Box 29, Norwich NR3 1GN Tel: 0870 600 5522 Fax: 0870 600 5533
e-mail: customer.services@tso.co.uk Website: www.tso.co.uk (They are also
available from bookshops.) Statutory Instruments can be viewed free of charge
at www.opsi.gov.uk.